



Project: _____

Item: _____

Quantity: _____

Date: _____

Models

- CP-STW-MF-90

Standard Features

- ✓ 14 gauge stainless steel top
- ✓ Molded fiberglass body
- ✓ 5" Locking Swivel Casters

Solid Top 90° Wedge Filler Unit
Molded Fiberglass (MF)

CP-STW-MF-90 shown with option: (SS) Stainless Steel Legs



- Upgrade directional flow in serving lines
- Makes a perfect 90° turn in any serving line
- Sanitary, easy to clean design

Specifications

Top - Top to be 30" wide and fabricated from a minimum of 14 gauge stainless steel with square turndown on all sides and corners fully welded, ground and polished. Top to have #4 satin finish.

Body (MF) - Body to be seamless molded fiberglass (F.R.P.) with smooth exterior surfaces and rounded corners. To be constructed by a hand lay-up process with four layers of 1.5 oz continuous strand fiberglass mat, plus a 24 oz layer of woven roving on the bottom for added strength. Fiberglass to be flame retardant per specification ASTM E-162 having a flame spread of 25% or less. Body interior to be reinforced at each end with 4 wide, 12 gauge galvanized channels welded to form integral U frame for maximum stress relief.

Options

Top Options

- Height Other Than Standard 36" (Specify _____)
- (MR) #7 Hi-Lite Edge

Tray Slide/Cutting Board Options

- (A) Beaded, Stainless Steel Tray Slide
- (B) Flat Surface, Stainless Steel Tray Slide
- (C) Tubular Stainless Steel Tray Slide

Base Options

- (MM) Vertical Trim Strips
- (SS) Stainless Steel Legs
- (TK) S/S Toe Kick

Electrical Options

- (DD) Convenience Outlet, Flush

A.I.A. File No. 00-0-00

SIS No. 00-0-00

REV 9/4/24



LTI, Inc.
1947 Bill Casey Parkway (888) 584-2722
Jonesboro, GA 30236 lowtempind.com

Approvals: _____

Solid Top 90° Wedge Filler Unit

Molded Fiberglass (MF)



Solid Top 90° Wedge Filler Unit
Molded Fiberglass (MF)

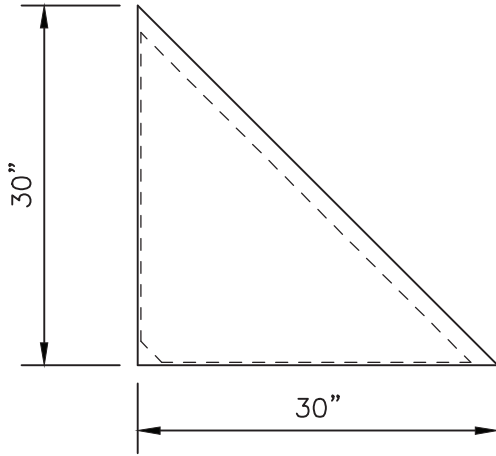

PLAN VIEW

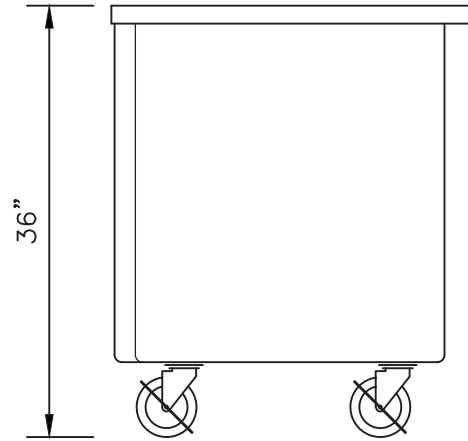

END VIEW

Model	L x W x H	Approx. Ship Weight
CP-STW-MF-90	30" x 30" x 36"	225 lbs.

Décor Options (Contact Factory)

- Vinyl Graphic
- Stand Off Panel
(Specify Materials _____)

We reserve the right to change specifications and product design without notice. Such revisions do not entitle the buyer to corresponding changes, improvements, additions or replacement for previously purchased equipment.

All equipment to be built in accordance with the Underwriters Laboratories, Inc. and the National Sanitation Foundation, Inc. standards and shall bear the Underwriters Laboratories, Inc. listing label for safety and the Underwriters Laboratories classification label for sanitation.

A.I.A. File No. 00-0-00

SIS No. 00-0-00

REV 9/4/24

LTI, Inc.
1947 Bill Casey Parkway
Jonesboro, GA 30236

(888) 584-2722
lowtempind.com



Changing
how food is served.™