



Changing
how food is served.

OPERATION/MAINTENANCE MANUAL



 **ThermalWell**[™]

DI-TW SERIES
HOT FOOD WELLS

CUSTOM FABRICATORS OF FOODSERVICE EQUIPMENT

1947 Bill Casey Parkway • Jonesboro, GA 30236
Tel: 770-478-8803 • Fax: 1 (770)-471-3715
www.lowtempind.com

Table of Contents

INSPECTION.....	3
SAFETY PRECAUTIONS.....	3
NOMENCLATURE.....	5
UNIT INSTALLATION INSTRUCTIONS / SPECIFICATION	6
OPERATING INSTRUCTIONS	9
Initial Setup/Prep Guidelines:	9
Powering On the Unit	9
Selecting the Heating Mode.....	10
Powering Off the Unit	10
Auto Setting on the Controllers	10
CLEANING INSTRUCTIONS.....	11
PREVENTATIVE MAINTENANCE	11
TROUBLESHOOTING.....	12
REPLACEMENT PARTS	13
WIRING DIAGRAMS.....	14
WARRANTY	16

INSPECTION

Upon receipt, the crate should be inspected for visual damage. Any damage should be reported immediately to the carrier.

SAFETY PRECAUTIONS

This manual includes safety and operating instructions for TW series hot food wells. LTI recommends reading all safety precautions and statements to ensure safe operation before installing and operating. Below are the precautions that are explained in more detail. Please read carefully.

DANGER

Danger warns of imminent hazard which will result in serious injury or death.

WARNING

Warning indicates the presence of a potential hazard or unsafe practice that will or can cause severe personal injury or death.

CAUTION

Caution indicate the presence of a hazard or unsafe practice that will or can cause minor or moderate personal injury if the caution is ignored.

NOTICE:

Used to note information that is important but not hazard-related.



WARNING

ELECTRIC SHOCK HAZARD

- Unit must be installed by a qualified electrician. Installation must conform to all local electrical codes. In the absence of local codes, use the latest version of the National Electrical Code.
- Unit should be safely and adequately grounded in accordance to local codes, or in the absence of local codes, the most up to date version of the National Electrical Code ANSI/NFPA70, to protect the user from electrical shock.
- The unit requires a grounded system and a dedicated circuit.
- The unit must be serviced by qualified personnel only. Service by unqualified personnel may lead to electric shock or burn.
- Control panel must be mounted on a vertical surface/wall and installed in the vertical position. Mounting control panel in the horizontal position may result in collection of liquids and lead to electrical shock.
- Turn OFF power, unplug power cord/turn off power at circuit breaker, and allow unit to cool if needed to before performing any cleaning, adjustments, or maintenance.

FIRE HAZARD

- Risk of fire do not install closer than 1 inch to sides and bottom of unit.
- Do not use flammable cleaning solutions to clean this unit.



CAUTION

BURN HAZARD

- Exterior surfaces on the unit may become hot. Use caution when touching these areas.
- Drain water may reach temperatures in excess of 200°F (93°C). use appropriate plumbing materials when installing drain lines.

NOTICE

- Units are voltage specific. Refer to specifications label for electrical requirements before installation.
- Use non-abrasive cleaners and cloths only. Abrasive cleaners and cloths could scratch finish of unit, marring its appearance and making it susceptible to soil accumulation.
- Do not use steel wool for cleaning.
- Do not use harsh chemicals such as bleach, cleaners containing bleach, or oven cleaners to clean this unit.

NOMENCLATURE

MODEL NOMENCLATURE:

DI – TW – DW – 20 – 04 – T
A B C D E F

A – DI = DROP-IN

B – TW = THERMALWELL

C – PAN STYLE

DW = DRY/WET

D = DRY

D – WIDTH OF PAN

20 – STANDARD 20"

12 – SLIM 12"

E – NUMBER OF STANDARD 12X20 PANS THE UNIT HOLDS

F – MOUNTING STYLE

T = TURN DOWN

H = HUGGED

UNIT INSTALLATION INSTRUCTIONS / SPECIFICATION

LTI: **TW Series** hot food drop-in units are designed for dispensing food. This unit is designed to help maintain product temperature at a minimum of 140 °F during serving periods. This unit is designed for temporary storage of product. They should not be used as long term storage of bulk product. Refer to figures and tables provided below for standard cut out sizes for the TW Series Drop-In units and controllers.

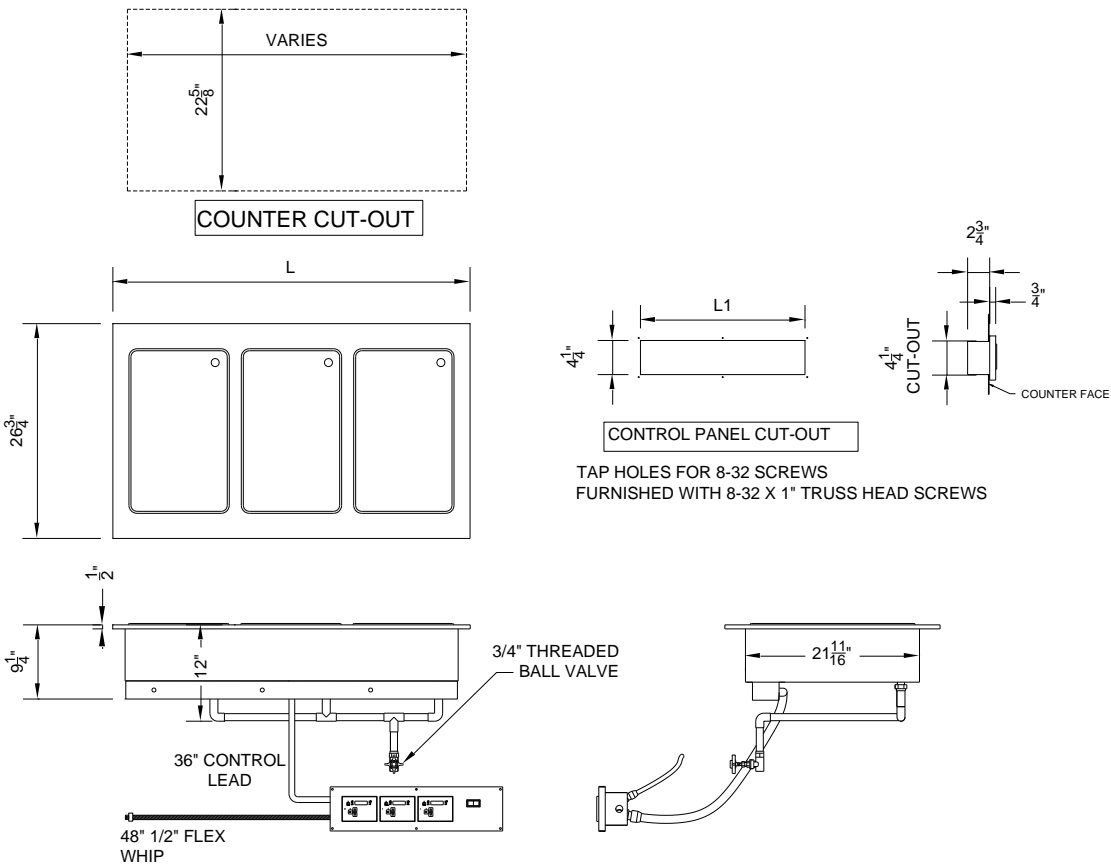

DI-TW MODEL DIMENSIONS					
MODEL #	PANS	L	COUNTER TOP CUT-OUT SIZE	L1 CONTROL PANEL LENGTH	CONTROL PANEL CUT-OUT SIZE
DI-TW-X-20-01-X	1	16 1/2"	22 5/8" X 14 1/4"	12"	11" X 4 1/4"
DI-TW-X-20-02-X	2	30 1/2"	22 5/8" X 28 1/4"	16 3/4"	15 3/4" X 4 1/4"
DI-TW-X-20-03-X	3	44 1/2"	22 5/8" X 42 1/4"	21 1/2"	20 1/2" X 4 1/4"
DI-TW-X-20-04-X	4	58 1/2"	22 5/8" X 56 1/4"	26 1/4"	25 1/4" X 4 1/4"
DI-TW-X-20-05-X	5	72 1/2"	22 5/8" X 70 1/4"	31"	30" X 4 1/4"
DI-TW-X-20-06-X	6	86 1/2"	22 5/8" X 84 1/4"	35 3/4"	34 3/4" X 4 1/4"

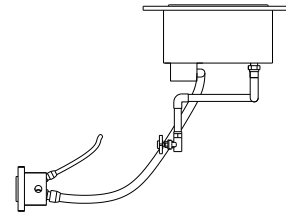
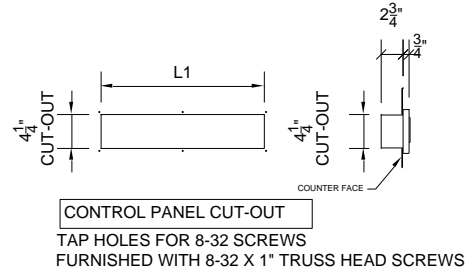
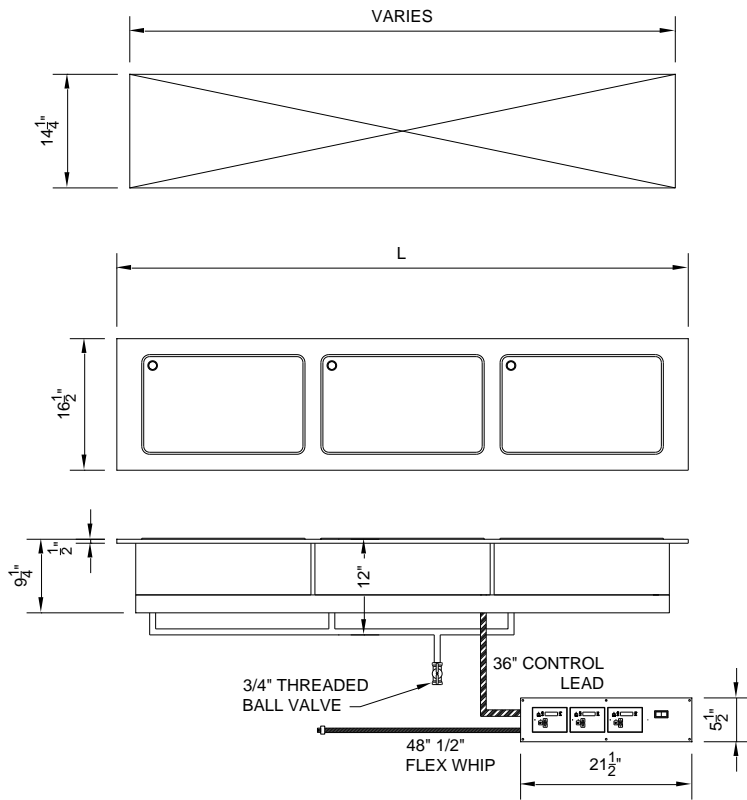

DI-TW SLIM MODEL DIMENSIONS					
MODEL #	PANS	L	COUNTER TOP CUT-OUT SIZE	L1 CONTROL PANEL LENGTH	CONTROL PANEL CUT-OUT SIZE
DI-TW-X-12-01-X	1	26 3/4"	14 1/4" X 22 5/8"	12"	11" X 4 1/4"
DI-TW-X-12-02-X	2	49 1/4"	14 1/4" X 46"	16 3/4"	15 3/4" X 4 1/4"
DI-TW-X-12-03-X	3	71 3/4"	14 1/4" X 68 1/2"	21 1/2"	20 1/2" X 4 1/4"
DI-TW-X-12-04-X	4	94 1/4"	14 1/4" X 91"	26 1/4"	25 1/4" X 4 1/4"
DI-TW-X-12-05-X	5	116 3/4"	14 1/4" X 113 1/2"	31"	30" X 4 1/4"

DI-TW SERIES ELECTRICAL RATINGS				
MODEL NO. (#)	VOLTS	PHASE	AMPS	WATTS
DI-TW-X-20-01-X	120	1	6.4	762
DI-TW-X-12-01-X	208-240	1	2.8 – 3.2	571-762
DI-TW-X-20-02-X	120	1	12.7	1524
DI-TW-X-12-02-X	208-240	2	5.5-6.4	1142-1524
	208-240	3	5.5-6.4	1142-1524
DI-TW-X-20-03-X	120	1	19.1	2286
DI-TW-X-12-03-X	208-240	2	8.2-9.5	1713-2286
	208-240	3	5.5-6.4	1713-2286
DI-TW-X-20-04-X	120	1	25.4	3049
DI-TW-X-12-04-X	208-240	2	11.0-12.7	2284-3049
	208-240	3	8.2-9.5	2284-3049
DI-TW-X-20-05-X	120	1	31.8	3811
DI-TW-X-12-05-X	208-240	2	13.7-15.9	2855-3811
	208-240	3	11.0-12.7	2855-3811
DI-TW-X-20-06-X	120	1	38.1	4573
	208-240	2	16.5-19.1	3426-4573
	208-240	3	11.0-12.7	3426-4573

Units are supplied with gasket perimeter material to prevent spillage into cabinet area. NSF grade silicone is recommended on sealing perimeter flange of drop-in to countertop.

Connect the unit into the proper grounded electrical service. Refer to unit's electrical data tag for correct electrical service requirements. The unit is now ready for operation.

*****WARNING*****

IN ORDER TO PREVENT ANY ELECTRICAL ACCIDENTS, THIS EQUIPMENT SHOULD BE INSTALLED AND SERVICED BY **QUALIFIED MAINTENANCE PERSONNEL ONLY** PER NATIONAL ELECTRICAL CODE STANDARDS.

OPERATING INSTRUCTIONS

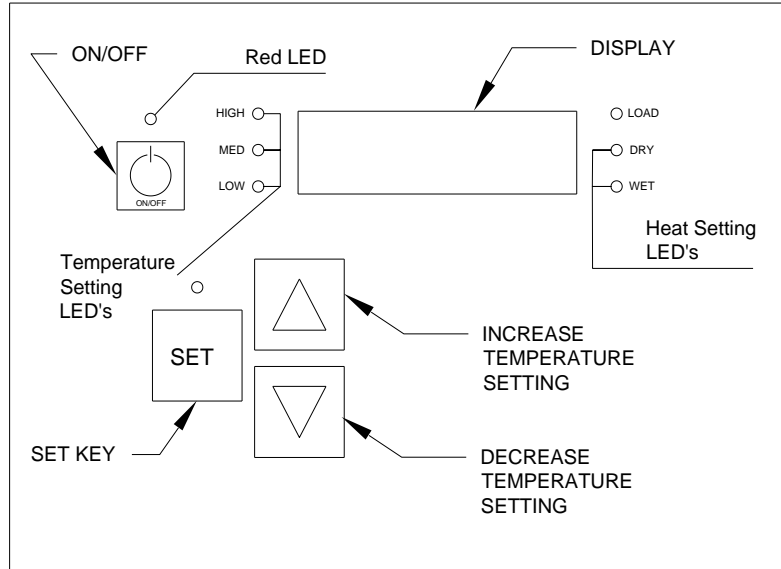

Initial Setup/Prep Guidelines:

- Wet Heat
 - Pour one gallon of water or roughly a 1" of water into each well before turning on the unit. DO NOT overfill well, this will cause poor performance of the well.
- Dry Heat
 - The use of water for the dry heat settings are not necessary.
- Never pour water into a preheated dry well.
- You must use a pan or lid over the well to reach the proper temperatures.
- Allow the well to preheat for 20 to 30 minutes before using.

Powering On the Unit

- Turn the unit on by switching the Master Switch to the ON position.
- Once on, the red LED light above ON/OFF will illuminate on each controller and OFF will appear on each screen.
- Press and hold the ON/OFF button for three seconds, h-1 OR the preset setting should appear on the screen and the unit will begin heating.

Selecting the Heating Mode

Changing Settings:

1. With the unit ON and running press and HOLD the SET key for 3 seconds.
2. The LED above the SET key will begin to blink.
3. QUICKLY (within 3sec) press the up or down key to select the desired setting that you would like to use.
4. Once the desired setting is selected you may press and hold the Set Key for 3 seconds or wait 3 seconds and the controller will begin running at the desired setting selected.

For settings and temperature ranges see table below.

TW CONTROL SETTINGS AND TEMPERATURE RANGES		
<u>SETTING</u>	<u>MODE</u>	<u>ELEMENT TEMP</u>
SouP	LOW	140°F
h-1	WET/LOW	250°F
h-2	WET/MED	265°F
h-3	WET/HIGH	290°F
H-4	DRY/LOW	390°F
H-5	DRY/MED	405°F
H-6	DRY/HIGH	420°F

Powering Off the Unit

- Press and hold the ON/OFF button for three seconds on each well or turn the main power switch to the OFF position.

Auto Setting on the Controllers

- Auto Restart Feature
 - The controllers can be pre-programmed for your next serving period ahead of time and will remember its settings for easy reuse.
 - Before you turn off the unit, set to the desired set points on the controllers for future use.
 - Next simply turn the power directly OFF from the Master Switch NOT the controllers themselves.
 - When you turn the Master Switch back to the ON position, "AUTO" will be displayed on the screen/screens of the controllers and will restart from the last set point that was selected.

CLEANING INSTRUCTIONS

To maintain the performance and finish of the unit clean the unit daily. Make sure to use cleaning supplies and cleaners designed for cleaning stainless-steel surfaces.

The factory recommends that mild soap and water be used to clean the wells.

Stainless steel:

Use soft cloths, microfiber, sponges, or plastic scouring pads. Avoid using scrapers wire brushes, steel wool or anything that might scratch the surface. Always clean stainless-steel parallel with the “grain”. Use cleaners that contain alkaline, alkaline chlorinated, or non-chloride chemicals.

PREVENTATIVE MAINTENANCE

To ensure that your equipment will continue to operate properly, please follow these simple steps:

1. The food wells should be cleaned thoroughly every day. Food spillage left in the pans such as tomato paste can cause damage to the unit. The acidic base of foods over time can cause pitting of the units.
2. Always wipe the unit down with a damp cloth. Do not spray water directly on the control panel areas or on areas with exposed heating elements.
3. Always drain the units of water at the end of each use and dry wells thoroughly to prevent containments from damaging the well

TROUBLESHOOTING

<u>COMPLIANT</u>	<u>PROBLEM</u>	<u>SOLUTION</u>
HOT FOOD UNIT WILL NOT HEAT	PLUG DISCONNECTED	CHECK ALL ELECTRICAL CONNECTIONS
	LINE SWITCH OPEN	CLOSE SWITCH
	BREAKER TRIPPED	RESET BREAKER
	HEATER DEFECTIVE	REPLACE HEATER
	LOW VOLTAGE	USING INSTRUMENT CHECK LINE VOLTAGE AND AMPERAGE. VOLTAGE MUST BE WITHIN 10% OF NAME PLATE RATING
CONTROLLER DISPLAYING "InIT"	TC NOT COMMUNICATING PROPERLY	CHECK CONNECTION POINTS OF THE TC TO THE CONTROLLER
	CONTROLLER NEEDS TO BE POLARIZED	RUN THROUGH THE POLARIZATION STEPS
	TC DISCONNECTED	CHECK CONNECTION/RECONNECT TC
CONTROLLER DISPLAYING "tc"	TC NOT COMMUNICATING PROPERLY	CHECK CORRECT OHMS. 3-4 OHMS AT AMBIENT CONDITIONS. REPLACE HEATER IF NEEDED
		CHECK CONNECTION POINTS OF THE TC TO THE CONTROLLER
	TC POLARITY INCORRECT	TC WIRES NEED TO BE REVERSED
	TC DISCONNECTED	CHECK CONNECTION/RECONNECT TC
CONTROLLER DISPLAYING "P1"	HEATER NOT HEATING/NOT SEEING TEMPERATURE RISE ABOVE 100°F WITHIN 5MIN	CHECK TO MAKE SURE POWER IS GOING TO HEATER POSSIBLE ISSUE WITH RELAY ON CONTROLLER. REPLACE CONTROL IF NEEDED
		CHECK FOR POSSIBLE DEFECTIVE HEATER. OHMS FOR HEATER SHOULD BE AROUND 90 OHMS AT AMBIENT FOR 208V UNIT AND 22 OHMS FOR 120V
		CHECK POLARITY OF THERMOCOUPLE PURPLE LEAD(+) & RED LEAD (-)
CONTROLLER DISPLAYING ER1	TC IS READING 0 VOLTS FOR 5 SECONDS WITH HEATERS ON	CHECK TC CONNECTIONS
	TC DISCONNECTED	CHECK CONNECTION/RECONNECT TC

REPLACEMENT PARTS

ITEM NO.	DESCRIPTION	STOCK NO.	MFG NO.	MANUFACTURER
1	H/F WELL MULTI VOLT/WATT WITH DRAIN	LTMWDRS		LTI
2	H/F WELL MULTI VOLT/WATT (NO DRAIN)	LTMWRS		LTI
3	HEATER/PLATE ASSEMBLY 72" LEAD	190010	LT0815SA	THERMO
4	HEATER PLATE COVER	190020	LT0815XX	THERMO
5	THERMAL WELL CONTROLLER	195443	330.2018.1	330 ELECTRONICS
6	ROCKER SWITCH 2PL-20A/277V	335917	TIGK721-6S-BL-NBL/ON-OFF	CARLING
7	CIRCUIT BREAKER, 1POLE 30AMP	332120	SQ "D" QOU-130	SQUARE D
8	CIRCUIT BREAKER, 1POLE 40AMP	332130	SQ "D" QOU-140	SQUARE D

WIRING DIAGRAMS

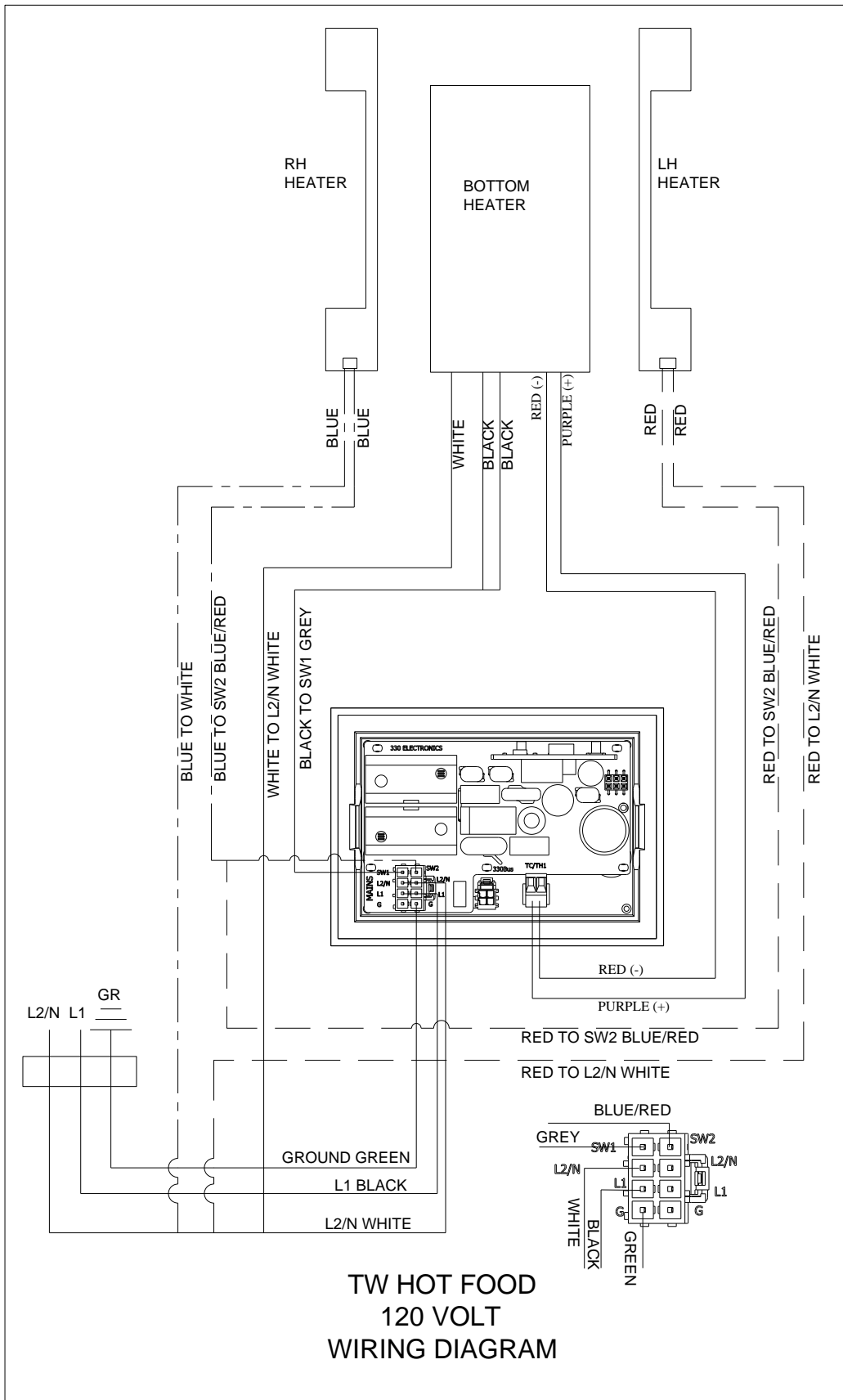

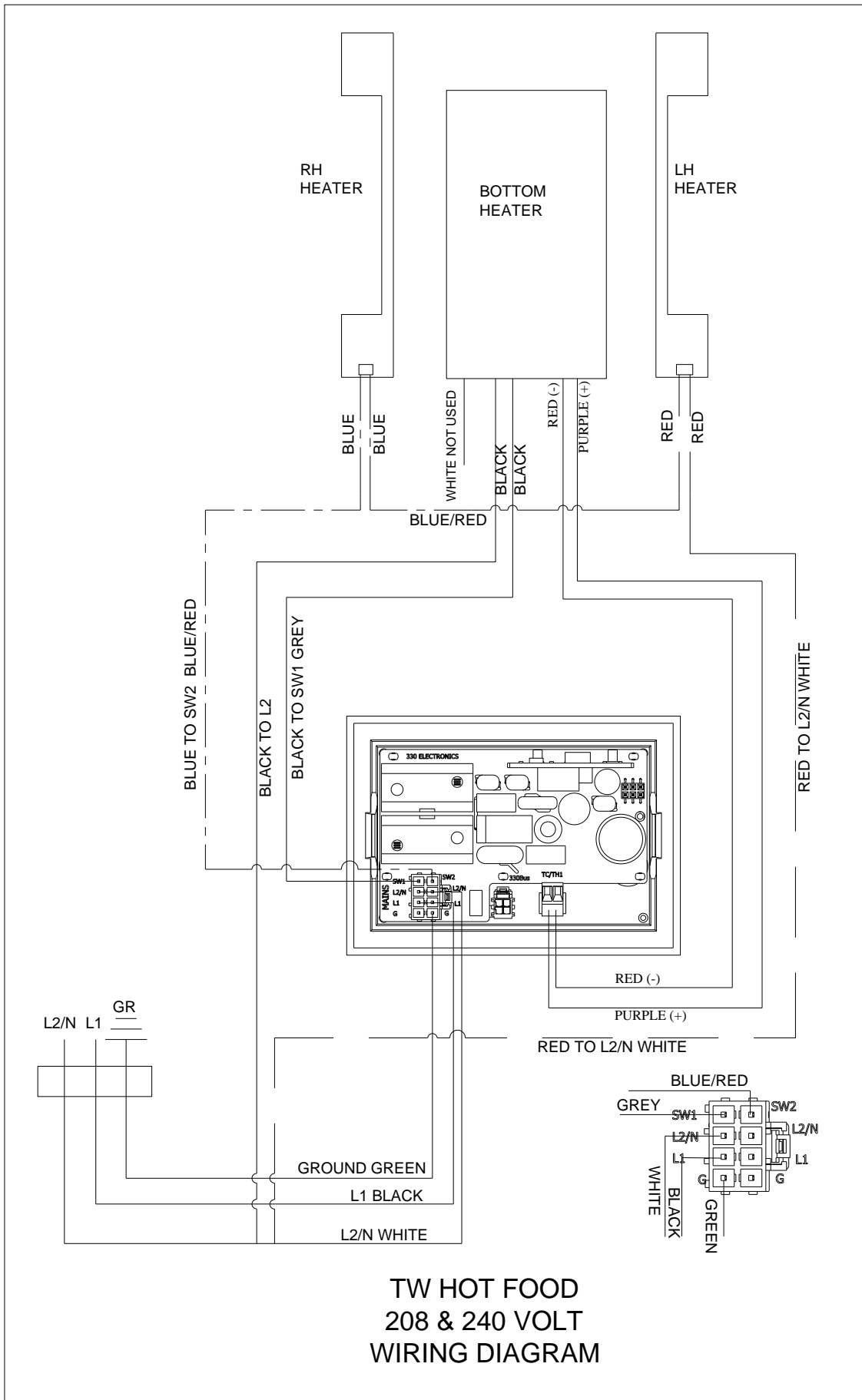

WARRANTY

Effective date July 1st, 2020

The LTI parts and labor warranty for all products is (1) year for all products (some product families have total of two-year parts and labor); The warranty period commences with the date of installation, or six (6) months from date of shipment from the factory, whichever is sooner. Refrigeration compressors come standard with a 5-year compressor warranty. The warranty covers all products used in United State and Canada. All labor and parts expense after the expiration of the warranty shall be the responsibility of the owner.

The QuickSwitch Family, TempestAir and ThermalWell families all include a 2yr parts and labor warranty.

K-12 warranty is 2 years parts and labor on ALL equipment.

All warranty labor is to be pre-authorized by the factory. To request warranty please go to <https://lowtempind.com/resources/warranty/> or call 888-584-2722 for pre-authorization and ask for the warranty department.

The warranty includes travel time to portal, not to exceed 100 miles round trip, or two hours total travel time. The warranty requires that all labor must be performed during regular work hours. Overtime premiums will be charged to the owner or must be pre-approved prior to the service call. The warranty does not apply to any equipment or component parts which have been subjected to shipping damage, improper voltage, improper installation, alteration, abuse, or misuse. The warranty does not cover routine maintenance activities, any failure that results from lack of, or improper equipment maintenance activities. The warranty does not cover any loss of business profits, any loss of food, or other products, or damage to property due to electrical, gas or mechanical malfunction or to any incidental or consequential damages of Purchaser or any third party. Damage due to floods, fire or other acts of God also are not covered.

Due to the custom nature of the products returns are not allowed. All inquiries concerning this warranty must be directed to LTI.

LTI

1947 Bill Casey Parkway • Jonesboro, GA 30236

Tel: 888-584-2722 • Fax: 1 (770)-471-3715

www.lowtempind.com