

ExpressLine COMPACT

Learn more at lowtempind.com/expresslinecompact

Small footprint, big solution



This compact counter is built with the same solid LTI construction and can now hold baskets for easy processing of hot or cold packaged foods.

This ExpressLine offers durable and flexible features such as heavy duty 14 gauge tops with solid sliding doors and two different body sizes to fit industry standard baskets. It allows for easy loading and unloading of products and has fully removable lids to ensure a speedy line.

Optional upper structures are able to support additional ambient merchandising. Menu boards and many exterior finishes are available to personalize the ExpressLine unit to fit your needs. A solid stainless push handle makes our ExpressLine Compact easy to move if remote feeding is required.

Optional elementary school height available.

Unit Size L x W x H	Description 12 Total Models	2-1/4" Deep Baskets	4-1/2" Deep Baskets
50" X 31" X 34"	Cold unit with slide lids	18	9
63" X 31" X 34"	Cold unit with slide lids	24	12
50" X 31" X 34"	Hot unit with slide lids	18	9
63" X 31" X 34"	Hot unit with slide lids	24	12

Notes: ¹Standard basket, 20-11/16" x 13-1/4". ²Extra wide basket, 26" x 13-1/4" in 36-5/8" deep units.

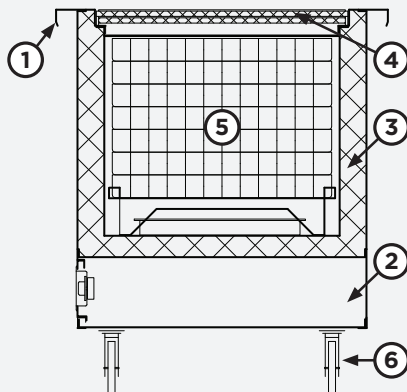

Unit cross-section

LEGEND

1. Standard 14ga top
2. 18ga galvanized steel body covered with standard grade plastic laminate panels
3. Heated liner shown - refrigerated units available also
4. 18ga stainless double pan insulated doors
5. Arlington or Standard baskets
6. 5" casters

STANDARD FEATURES

- Operators can serve hundreds of meals and snacks
- Made of stainless steel and easy to clean
- Mobility - can easily be moved from courtyards to classrooms and everywhere in between
- Customizable upper structures for display of additional items