



Project: _____

Item: _____

Quantity: _____

Date: _____

Models

SPC-STW-LP/SS-45

Standard Features

- ✓ 14 gauge stainless steel top
- ✓ 5" Locking Swivel Casters

Solid Top 45° Wedge Filler Unit
Laminate Panel (LP) or Stainless Steel (SS)

SPC-STW-LP/SS-45 shown with option: (SS) Stainless Steel Legs.



- Upgrade directional flow in serving lines
- Makes a perfect 45° turn in any serving line
- Sanitary, easy to clean design

Specifications

Top - Top to be 32" wide and fabricated from a minimum of 14 gauge stainless steel with square turndown on all sides and corners fully welded, ground and polished. Top to have #4 satin finish.

Body (LP) - Standard grade laminate to cover all sides of an 18 gauge steel uni-body structure. Interior reinforced with 12 gauge galvanized uprights to support shelving and a 11 gauge steel bottom. Corners provided with 3/4" stainless steel trim strips, and bottom edge provided with 1/2" aluminum mop guard.

Body (SS) - Uni-body structure, fabricated from 18 gauge stainless steel, welded ground and polished. Interior reinforced with 12 gauge galvanized uprights to support shelving and an 11 gauge steel bottom.

Options

Top Options

- Height Other Than Standard 36" (Specify _____)
- (MR) #7 Hi-Lite Edge

Tray Slide/Cutting Board Options

- (A) Beaded, Stainless Steel Tray Slide
- (B) Flat Surface, Stainless Steel Tray Slide
- (C) Tubular Stainless Steel Tray Slide
- (FTS) Fixed Tray Slide

Base Options

- (MM) Vertical Trim Strips
- (SS) Stainless Steel Legs
- (TK) S/S Toe Kick

Electrical Options

- (DD) Convenience Outlet, Flush

A.I.A. File No. 00-0-00

SIS No. 00-0-00

REV 9/4/24



LTI, Inc.
1947 Bill Casey Parkway (888) 584-2722
Jonesboro, GA 30236 lowtempind.com

Approvals: _____

Solid Top 45° Wedge Filler Unit

Laminate Panel (LP) or Stainless Steel (SS)

Solid Top 45° Wedge Filler Unit
Laminate Panel (LP) or Stainless Steel (SS)

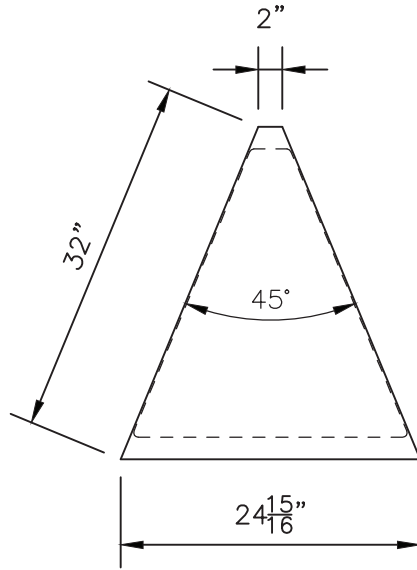

PLAN VIEW

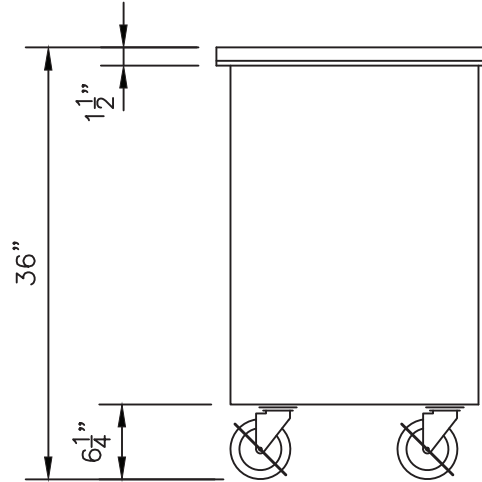

OPERATOR VIEW

Model	L x W x H	Approx. Ship Weight
SPC-STW-LP/SS-45	25" x 32" x 36"	175 lbs.

Décor Options (Contact Factory)

- Vinyl Graphic
- Stand Off Panel
(Specify Materials _____)

We reserve the right to change specifications and product design without notice. Such revisions do not entitle the buyer to corresponding changes, improvements, additions or replacement for previously purchased equipment.

All equipment to be built in accordance with the Underwriters Laboratories, Inc. and the National Sanitation Foundation, Inc. standards and shall bear the Underwriters Laboratories, Inc. listing label for safety and the Underwriters Laboratories classification label for sanitation.

A.I.A. File No. 00-0-00

SIS No. 00-0-00

REV 9/4/24

