



36-CSE-L shown with options: (A) beaded stainless steel tray slide, and (HH) locking cash drawer.



- Versatile counters, add the options you need!
- Easy to clean, low maintenance
- 50" and longer units can contain a drop-in freezer/merchandiser or display shelves for added versatility.

Project: _____

Item: _____

Quantity: _____

Date: _____

Models

- 28-CSE-L/S - end station
- 36-CSE-L/S - end station
- 50-CSE-L/S - end station
- 60-CSE-L/S - end station
- 66-CSE-L/S - end station
- 74-CSE-L/S - end station
- 28-CSS-L/S - side station
- 36-CSS-L/S - side station
- 50-CSS-L/S - side station
- 60-CSS-L/S - side station
- 66-CSS-L/S - side station
- 74-CSS-L/S - side station

Standard Features

- ✓ 30" wide 14 gauge stainless steel top
- ✓ Tubular footrest
- ✓ 5" Locking Swivel Casters
- ✓ Cam locking Line-up Lock

Specifications

Top - Top to be 30" wide and fabricated from a minimum of 14 ga. stainless steel with square turndown on all sides and corners fully welded, ground and polished. Top to have #4 satin finish and with all edges having a #7 hi-lite finish.

Body (S) - Uni-body structure, fabricated from 18 gauge stainless steel, welded ground and polished. Interior reinforced with 12 gauge galvanized uprights to support shelving and a 20 gauge steel bottom.

Body (L) - Standard grade laminate to cover all sides of an 18 gauge steel uni-body structure. Interior reinforced with 12 gauge galvanized uprights to support shelving and a 20 gauge steel bottom. Corners and bottom edge provided with 1/2" stainless steel trim strips.

Options

Top

- Height other than standard 36" (specify _____)
- Keypad bracket

Above the Top (50" and longer units)

- (F) Overshelf
- (G) Sloped Front Protector
- (GA) Sloped Front Protector, Adjustable
- (GAG) Sloped Front Protector - Adjustable - Glass Top Shelf
- (GC) Sloped Front Protector, Glass Clips
- (GCG) Sloped Front Protector - Glass Clips - Glass Top Shelf
- (M) Buffet Shield Single Service Hinged
- (N) Buffet Shield Double Service Hinged
- (GTS) Glass Top Shelf for Protector or Buffet Shield
- (I) 2 tier Display Shelf, single service

- (I2) 2 tier Display Shelf, double service
- (SCP) Straight Tempered Glass Protector
- (RR) LED Lights

Tray Slide/Cutting Board Options

- (A) Beaded, stainless steel tray slide
- (B) Flat Surface, stainless steel tray slide
- (C) Tubular Solid Surface, stainless steel tray slide
- (D) 8" wide Stainless Steel cutting board
- (E) 8 wide Richlite® composite cutting board

Plumbing & Electrical Options

- (DD) Convenience outlet, flush
- (EE) Convenience outlet, pedestal

Base Options

- (Y) Hinged Doors
- (MM) Vertical Trim Strips
- (SS) Stainless Steel Legs

- Slide-out shelf
- Locking cabinet
- Security cover
- Powder Coat Louvers (specify RAL # _____)
- S/S Toe Kick

Cash Drawer Options

- (HH) Locking Cash Drawer
- Plastic cash tray
- Other (specify _____)

Cashier Station
Stainless Steel (S) or Laminate Panel (L)

A.I.A. File No. 00-0-00

SIS No. 00-0-00

REV 11/8/19 - Printed in the U.S.A.

Approvals: _____

Cashier Station

Stainless Steel (S) or Laminate Panel (L)



Cashier Station

Stainless Steel (S) or Laminate Panel (L)

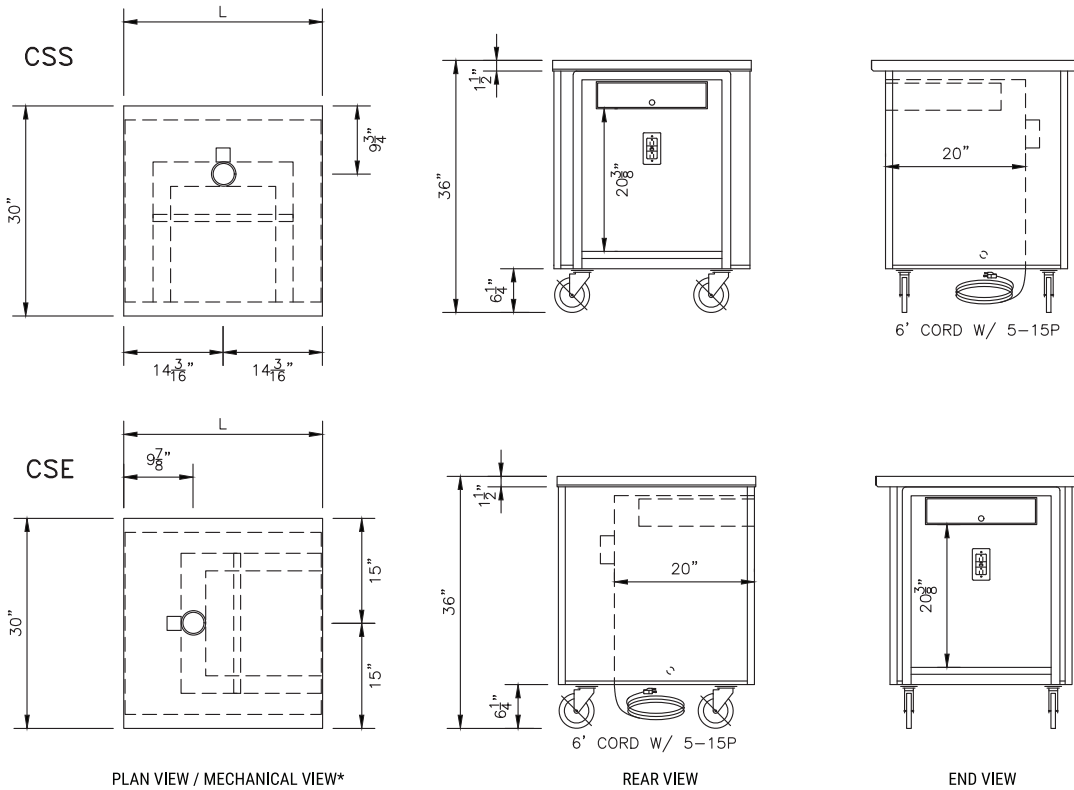

*Shown with optional cashier drawer & receptacle with cord and plug.

CSE Models	L	S*	APPROX. SHIP WEIGHT
28-CSE	28 3/8"	N/A	205 lbs.
36-CSE	36 3/8"	N/A	260 lbs.
50-CSE	50 3/8"	15"	320 lbs.
60-CSE	60 3/8"	28"	440 lbs.
66-CSE	66 3/8"	36"	480 lbs.
74-CSE	74 3/8"	46"	540 lbs.

CSS Models	L	S (optional)	APPROX. SHIP WEIGHT
28-CSS	28 3/8"	N/A	205 lbs.
36-CSS	36 3/8"	N/A	260 lbs.
50-CSS	50 3/8"	15"	320 lbs.
60-CSS	60 3/8"	28"	440 lbs.
66-CSS	66 3/8"	36"	480 lbs.
74-CSS	74 3/8"	46"	540 lbs.

* Represents optional storage compartment mounted in 50" or longer units.

Décor Options (Contact Factory)

- Vinyl Graphic Wrap
- Body Decal
- Canopy (specify style & color)
- Over-structure with signage & lights (specify _____)
- Stand Off Panel (specify materials _____)

We reserve the right to change specifications and product design without notice. Such revisions do not entitle the buyer to corresponding changes, improvements, additions or replacement for previously purchased equipment.

All equipment to be built in accordance with the Underwriters Laboratories, Inc. and the National Sanitation Foundation, Inc. standards and shall bear the Underwriters Laboratories, Inc. listing label for safety and the Underwriters Laboratories classification label for sanitation.

A.I.A. File No. 00-0-00

SIS No. 00-0-00

REV 11/8/19 - Printed in the U.S.A.

LTI, Inc.
1947 Bill Casey Parkway
Jonesboro, GA 30236

(888) 584-2722
lowtempind.com



Changing
how food is served.™