

# Quick Switch 2-Tier Ceramic Glass Shelf Table



Stainless Steel (S) or Laminate Panel (L)



QSGT-42-2T-BI-S shown with options: (CT) Corian® top, (TE) top width extension, and (RR) LED lights.

**Project:** \_\_\_\_\_

**Item:** \_\_\_\_\_

**Quantity:** \_\_\_\_\_

**Date:** \_\_\_\_\_

**Models                      Length**

- QSGT-28-2T-L/S            36"
- QSGT-42-2T-L/S            50"

**Standard Features**

- ✓ Solid state digital controls
- ✓ On/off lighted rocker switch for cold/frost mode
- ✓ 30" wide 14 gauge stainless steel top
- ✓ 5" Locking Swivel Casters

**Top Options**

- Operator service top shelf with full glass front
- Height other than std 36" (specify \_\_\_\_\_)
- (TEW) Top Extensions (width \_\_\_\_\_)
- (TEL) Top Extensions (length \_\_\_\_\_)
- (CT) Corian® Top (specify \_\_\_\_\_)
- (QT) Stone Top (specify \_\_\_\_\_)
- (AA) Cam Operated Line-up Locks
- (FF) End Drop Shelf
- (RR) LED Lights
- (S) Infra-Red Lamp Strip
- (T) Bullet Type Heat Lamps
- (U) Infra-Red Strip with Lights

**Above the Top**

- (RR) LED Lights
- (S) Infra-Red Lamp Strip
- (U) Infra-Red Strip with Lights

**Tray Slide / Cutting Board Options**

- (A) Beaded, stainless steel tray slide
- (B) Flat Surface, stainless steel
- (C) Tubular stainless steel
- (CTS) Corian® Tray Slide (specify \_\_\_\_\_)
- (QTS) Stone Tray Slide (specify \_\_\_\_\_)

- Powder Coated brackets (specify RAL # \_\_\_\_\_)
- (D) 8" wide Stainless Steel cutting board
- (E) 8" wide Richlite® composite cutting board
- Other cutting board width (specify \_\_\_\_\_)

**Base Options**

- (EB) Enclosed Base - no under storage
- (Y) Hinged Doors
- (BB) Heated Storage Base
- (CC) Refrigerated Storage Base
- (MM) Vertical Trim Strips
- (SS) Stainless Steel Legs
- (OP) Offset Panels
- S/S Toe Kick
- (IU) Intermediate Undershelf
- Other \_\_\_\_\_

**Plumbing & Electrical Options**

- (DD) Convenience outlet, flush
- (EE) Convenience outlet, pedestal
- (DC) Daisy chain
- (LC) Load center
- (TL) Twist Lock Plug & Matching Receptacle
- ¼" Turn Ball Valve
- Alternate Drain Location \_\_\_\_\_

**Other Options (Contact Factory)**

- Vinyl Graphic Wrap
- Body Decal

- ▶ First of its kind speckled glass masks scratches
- ▶ Upper and lower shelves independently controlled
- ▶ Heated shelf to frost top with the flip of a switch
- ▶ Sanitary and easy-to-clean glass maximizes product merchandising
- ▶ New heat blanket technology ensures even heat across entire surface
- ▶ Elevated shelf has stainless steel housing for heat/cool components
- ▶ Low profile 1 3/4 " stainless flange sits flush with the counter
- ▶ Gutter in flange allows drainage of condensation
- ▶ Bottom shelf allows unwrapped bulk foods as well as portioned products

- Canopy (specify style & color)
- Over-structure with signage & lights (specify \_\_\_\_\_)
- Digital Menu Boards
- Progressions Décor Panel



LTI, Inc.  
P.O. Box 795  
Jonesboro, GA 30237  
T 770 478 8803  
F 770 471 3715  
W lowtempind.com



U.L. Sanitation Classified to NSF Standards

REV 11/11/16

# Quick Switch 2-Tier Ceramic Glass Shelf Table



Stainless Steel (S) or Laminate Panel (L)

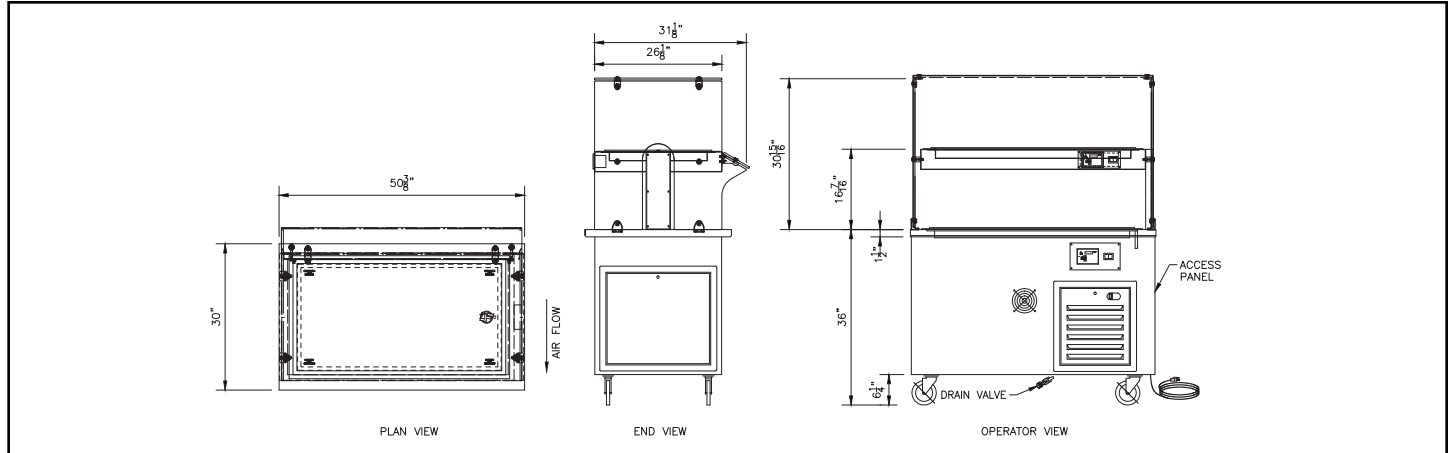

Model #	Stainless Steel Top		Solid Surface		Heated Area	120V/1		Refrigerant
	L	L1	L	L1		Amps	Plug	
QSGT-28-2T-BI	36"	32 1/8"	37 1/2"	33 5/8"	1232 sq/in	11.0	5-15P	R507
QSGT-42-2T-BI	50"	46 1/8"	51 1/2"	47 5/8"	1848 sq/in	11.0	5-15P	R507

## Specifications

Unit to have two food safe ceramic glass shelves. Glass to be 1/4" thick and be UL recognized. 600 watt silicone heat blanket to be attached to the underside of the glass with high temperature adhesive. Refrigerant tubing and heating element to be incased in a heavy duty stainless steel framework and foamed in place with high density polyurethane foam. Upper shelf framework to be encased in 16 gauge housing with a #4 mill finish. Shelves to have a tempered glass food protector/display case. All glass to be 3/8" tempered and meet ANSI A97.1 specifications for safety performance and ASTM C1048-04 specifications for heat treated glass. All component hardware to be CNC machined in 6061-T6 aluminum to +/- .002" and be finished in satin clear anodized aluminum. Unit to include two solid state digital controllers for hot operation and two lighted on/off rocker switch for cold operation. Controller to be mounted on the operator's side on counter apron. Counter to have a properly sized self-contained refrigeration system complete with controls and operate on R-507 (HFC) refrigerant.

## Top

Top to be 30" wide and fabricated from a minimum of 14 gauge stainless steel with square turndown on all sides and corners fully welded, ground and polished. Top to have #4 satin finish and with all edges having a #7 hi-lite finish.

## Body (S)

Uni-body structure, fabricated from 18 gauge stainless steel, welded ground and polished. Interior reinforced with 12 gauge galvanized uprights to support shelving and a 20 gauge steel bottom.

## Body (L)

Standard grade laminate to cover all sides of an 18 gauge steel uni-body structure. Interior reinforced with 12 gauge galvanized uprights to support shelving and a 20 gauge steel bottom. Corners and bottom edge provided with 1/2" stainless steel trim strips.

## Casters

5" diameter, ball bearing, swivel type casters to be non-marking and with brakes on all wheels. Casters to be mounted though two 12 gauge channels for extra rigidity.

We reserve the right to change specifications and product design without notice. Such revisions do not entitle the buyer to corresponding changes, improvements, additions or replacement for previously purchased equipment.

All equipment to be built in accordance with the Underwriters Laboratories, Inc. and the National Sanitation Foundation, Inc. standards and shall bear the Underwriters Laboratories, Inc. listing label for safety and the Underwriters Laboratories classification label for sanitation.

REV 11/11/16



LTI, Inc.  
P.O. Box 795  
Jonesboro, GA 30237

T 770 478 8803  
F 770 471 3715  
W lowtempind.com



U.L. Sanitation Classified to NSF Standards