

Project: _____

Item: _____

Quantity: _____

Date: _____

Models	Length
<input type="checkbox"/> CPM-HNS-2-0915	9" x 15"
<input type="checkbox"/> CPM-HNS-2-0915	10" x 14"
<input type="checkbox"/> CPM-HNS-2-0915	12 1/4" x 15 1/2"
<input type="checkbox"/> CPM-HNS-2-0915	14" x 18"
<input type="checkbox"/> CPM-HNS-2-0915	15 1/2" x 20 1/2"
<input type="checkbox"/> CPM-HNS-2-0915	16" x 22"
<input type="checkbox"/> CPM-HNS-2-0915	17 1/2" x 21"

Tray, Silverware, Napkin Dispenser

CPM-HNS-2-0915



U.L. Sanitation Classified to NSF Standards

- Heavy duty stainless steel construction
- Large capacity
- Sizes to fit virtually all trays
- Mobile, easy to move from dish-room to serving area
- Easy to clean design

Standard Features

- ✓ Self-leveling dispensers
- ✓ Corner bumpers
- ✓ 4" swivel casters with brakes

Optional Features (specify)

- (TT) Wrap-around bumpers
- 5" Swivel casters

A.I.A. File No. 00-0-00

SIS No. 00-0-00

REV 1/30/19 - Printed in the U.S.A.



LTI, Inc.
1947 Bill Casey Parkway (888) 584-2722
Jonesboro, GA 30236 lowtempind.com

Approvals: _____

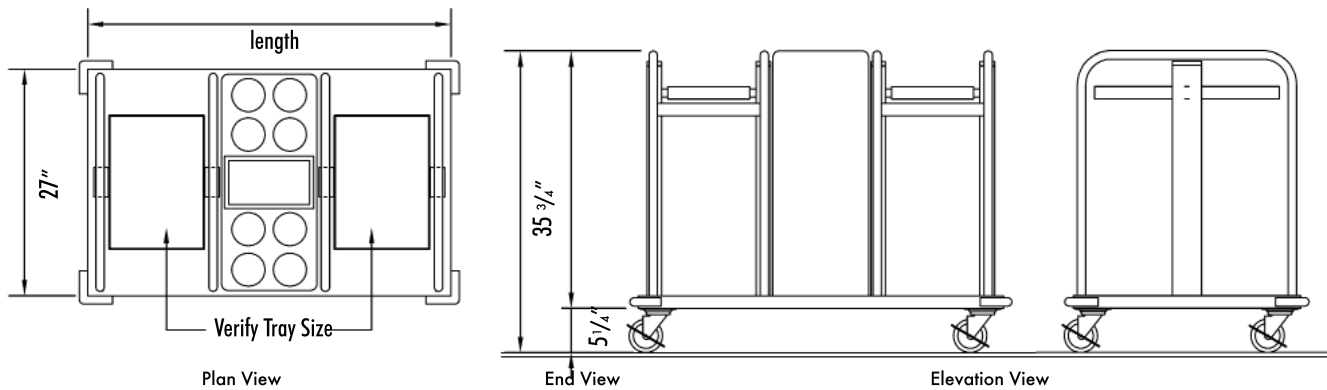

Note: Add 2" for corner bumpers

Model	Length	Tray Size	Tray Capacity*	Tray Stacks	Approx. Ship Weight
CPM-HNS-2-0915	43 ³ / ₄ "	9" x 15"	300	2	85 lbs.
CPM-HNS-2-1014	43 ³ / ₄ "	10" x 14"	300	2	85 lbs.
CPM-HNS-2-1216	47 ³ / ₄ "	12 ¹ / ₄ " x 16 ¹ / ₂ "	300	2	100 lbs.
CPM-HNS-2-1418	51 ³ / ₄ "	14" x 18"	300	2	136 lbs.
CPM-HNS-2-1520	54 ¹ / ₂ "	15 ¹ / ₄ " x 20 ¹ / ₂ "	300	2	138 lbs.
CPM-HNS-2-1622	56 ¹ / ₂ "	16" x 22"	300	2	148 lbs.
CPM-HNS-2-1821	60 ¹ / ₂ "	17 ¹ / ₂ " x 21"	300	2	152 lbs.

* Tray capacity may vary depending on stacking height of trays.

NOTE: When ordering, please verify exact length, width, weight of one tray for proper calibration.

Base and Frame

Base to be fabricated from heavy gauge stainless steel with all sides turned square with all corners fully welded, ground and polished. Underside reinforced with heavy gauge channels. Base to have non-marking corner bumpers. Frame shall be constructed of 1" O.D. 16 gauge stainless steel tubing bolted to the base.

Silverware and Napkin Dispenser

Center pylon shall be seamless molded fiberglass (F.R.P) with smooth exterior surfaces and rounded corners. Top to have eight (8) cut outs complete with nylon silverware cylinders and one (1) 1/4 size x 6" deep pan for napkins. All fiberglass to be flame retardant per specification ASTM E-162 having a flame spread of 25 or less.

Dispenser Mechanism

Easily removable self-leveling mechanisms shall be field adjustable without the use of tools and shall be supplied with a stainless steel tray platform.

Casters

4" diameter, ball bearing, swivel type casters to be non-marking and with brakes on all wheels.

We reserve the right to change specifications and product design without notice. Such revisions do not entitle the buyer to corresponding changes, improvements, additions or replacement for previously purchased equipment.

All equipment to be built in accordance with the Underwriters Laboratories, Inc. and the National Sanitation Foundation, Inc. standards and shall bear the Underwriters Laboratories, Inc. listing label for safety and the Underwriters Laboratories classification label for sanitation.