



Project: _____

Item: _____

Quantity: _____

Date: _____

Models	Tray Size
<input type="checkbox"/> TD-1014	10" x 14"
<input type="checkbox"/> TD-1020	10" x 20"
<input type="checkbox"/> TD-1418	14" x 18"
<input type="checkbox"/> TD-1620	16" x 20"
<input type="checkbox"/> TD-1622	16" x 22"
<input type="checkbox"/> TD-2020	20" x 20"

TD-1418 shown with option: (YY) Laminate plastic body panels



- Heavy duty stainless steel construction
- Large capacity
- Sizes to fit virtually all trays
- Mobile, easy to move from dish-room to serving area
- Easy to clean design

Standard Features

- ✓ 14 gauge stainless steel top
- ✓ Self-leveling dispensers
- ✓ Corner bumpers
- ✓ Stainless steel body with fiberglass panels
- ✓ 4" swivel casters with brakes

Optional Features

- Height other than standard 36" (specify _____)
- (MM) Vertical Trim Strips
- (OO) Silverware dispenser
- (PP) Napkin dispenser
- (SS) Stainless Steel Legs
- (TT) Wrap-around bumper
- (YY) Laminate plastic body panels
- (ZZ) Stainless steel body panels
- S/S Toe Kick
- 5" swivel casters

Other Options (Contact Factory)

- Body Decal
- Canopy (specify style & color)
- Over-structure with signage & lights (specify _____)
- Digital Menu Boards
- Décor Panel

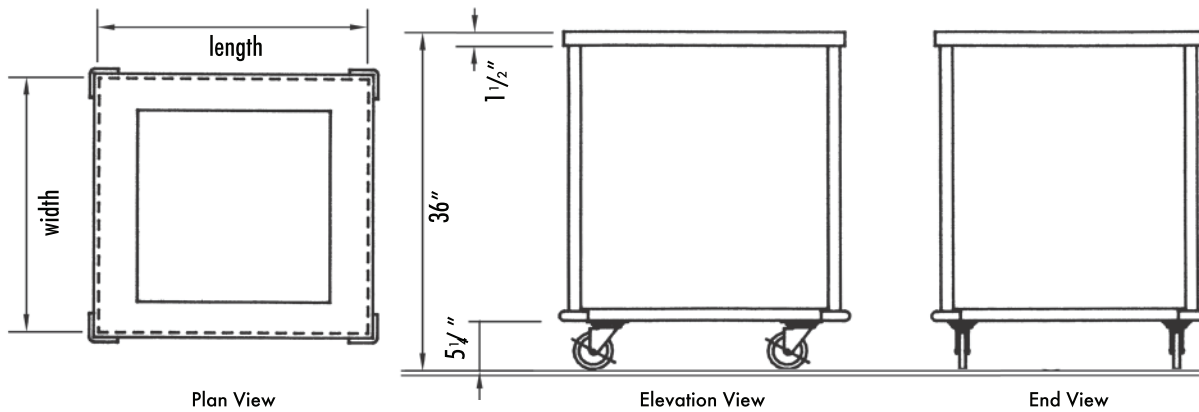

Note: Add 2" for corner bumpers

Model	Length x width x height	Tray Size	Approx. Ship Weight
TD-1014	23" x 18" x 36"	10" x 14"	140 lbs.
TD-1020	29" x 23 1/4" x 36"	10" x 20"	105 lbs.
TD-1418	29" x 23 1/4" x 36"	14" x 18"	115 lbs.
TD-1620	29" x 23 1/4" x 36"	16" x 20"	130 lbs.
TD-1622	31" x 23 1/4" x 36"	16" x 22"	130 lbs.
TD-2020	29" x 27 1/4" x 36"	20" x 20"	145 lbs.

NOTE: When ordering, please specify body panel color and optional extras.

Top

Top fabricated from a minimum of 14 gauge stainless steel with square turndown on all sides and corners fully welded, ground and polished. Top to have #4 satin finish and all edges having #7 hi-lite finish

Body and Frame

Frame to be 14 gauge stainless steel construction. Full perimeter top and bottom frame fully welded, ground and polished to vertical corner uprights making body frame one integral unit. Non-marking corner bumpers secured to bottom frame. Body panels to be fiberglass reinforced polyester (F.R.P.) with smooth exterior surface. All fiberglass to be flame retardant per specification ASTM E-162 having a flame spread of 25 or less.

Dispensers

The top opening shall contain a stainless steel self-leveling dispenser. Dispensing mechanism shall be constructed with automatic self-leveling elevators, enclosed in a stainless steel housing. The elevator mechanisms shall be field adjustable without the use of tools and be connected to a removable heavy gauge stainless steel carrier.

Casters

4" diameter, ball bearing, swivel type casters to be non-marking and with brakes on all wheels.

We reserve the right to change specifications and product design without notice. Such revisions do not entitle the buyer to corresponding changes, improvements, additions or replacement for previously purchased equipment.

All equipment to be built in accordance with the Underwriters Laboratories, Inc. and the National Sanitation Foundation, Inc. standards and shall bear the Underwriters Laboratories, Inc. listing label for safety and the Underwriters Laboratories classification label for sanitation.