

# Combo Milk and Ice Cream Dispenser

Molded Fiberglass (F), Stainless Steel (S), or Laminate Panel (L)



CTAD-74-F

**Project:** \_\_\_\_\_

**Item:** \_\_\_\_\_

**Quantity:** \_\_\_\_\_

**Date:** \_\_\_\_\_

Models	Length
<input type="checkbox"/> CTAD-66-F/L/S	66 3/8"
<input type="checkbox"/> CTAD-74-F/L/S	74 3/8"

**Standard Features**

- ✓ 30" wide 14 gauge stainless steel top
- ✓ Insulated stainless steel hinged doors
- ✓ Self-leveling dispensers
- ✓ 6 stainless steel trays per compartment
- ✓ Welded stainless steel interior
- ✓ 5" swivel casters

**Optional Features (specify)**

- Height other than standard 36 (specify \_\_\_\_\_)
- (A) Beaded, stainless steel tray slide
- (B) Flat Surface, stainless steel tray slide
- (C) Tubular stainless steel tray slide
- (CTS) Corian® Tray Slide
- (QTS) Stone Tray Slide
- Powder Coated brackets (specify RAL # \_\_\_\_\_)
- (D) 8" wide Stainless Steel cutting board
- (E) 8" wide Richlite® composite cutting board
- Other cutting board width (specify \_\_\_\_\_)

- (AA) Cam Operated Line-up Locks
- (DD) Convenience outlet, flush
- (EE) Convenience outlet, pedestal
- (FF) End Drop Shelf
- (MM) Vertical Trim Strips
- (SS) Stainless Steel Legs
- (DC) Daisy chain
- (LC) Load center
- Powder Coat Louvers (specify RAL # \_\_\_\_\_)
- S/S Toe Kick
- Custom Body Color (specify RAL # \_\_\_\_\_)

**Other Options (Contact Factory)**

- Vinyl Graphic Wrap
- Body Decal
- Canopy (specify style & color)
- Over-structure with signage & lights (specify \_\_\_\_\_)
- Digital Menu Boards
- Progressions Décor Panel

- ▶ Ice cream and milk in one convenient unit
- ▶ Large capacity of half pint cartons
- ▶ Durable and easy to clean
- ▶ Easy mobility
- ▶ Cartons kept at easy-to-reach height

# Combo Milk and Ice Cream Dispenser

Molded Fiberglass (F) or Stainless Steel (S)

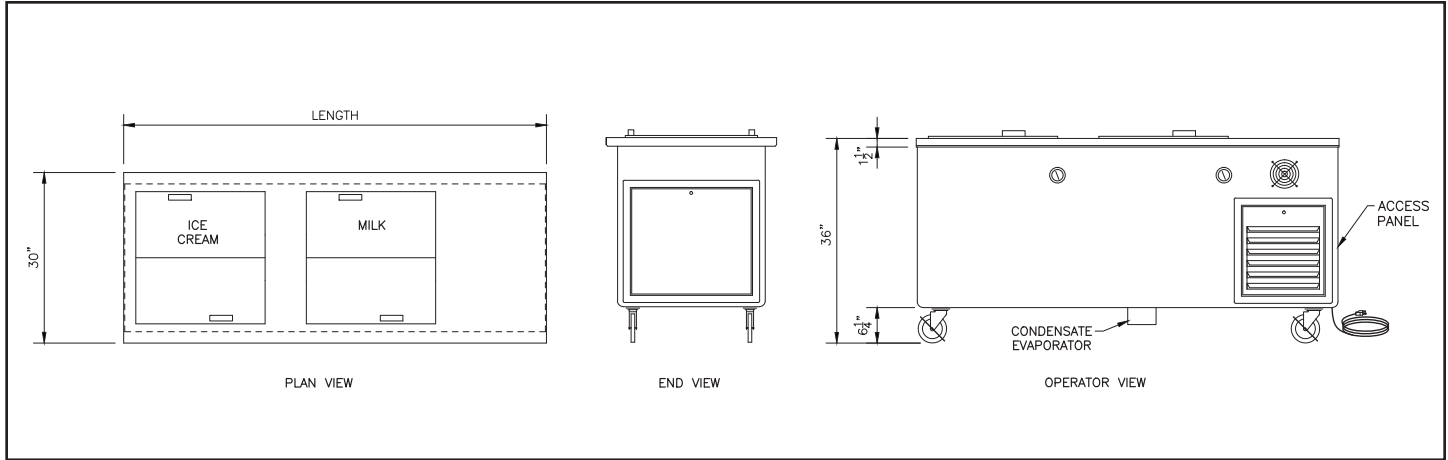

Model #	Length	Tray Size	Top Openings	Milk Capacity using 1/2 pt cartons	Ice Cream Capacity using 3 oz cups	Comp.	120V/1 phase		Ship Weight
							Amps	Plug	
CTAD-66	66 3/8"	one - 10x20 - freezer one - 20x20 - refrigerator	2	364	320	1/2 H.P.	16.0	5-20P	550 lbs.
CTAD-74	74 3/8"	one - 20x20 - freezer one - 20x20 - refrigerator	2	364	672	1/2 H.P.	16.0	5-20P	600 lbs.

**Body (S)**

Uni-body structure, fabricated from 18 gauge stainless steel, welded ground and polished. Interior reinforced with 12 gauge galvanized uprights to support shelving and a 20 gauge steel bottom.

**Body (L)**

Standard grade laminate to cover all sides of an 18 gauge steel uni-body structure. Interior reinforced with 12 gauge galvanized uprights to support shelving and a 20 gauge steel bottom. Corners and bottom edge provided with 1/2" stainless steel trim strips.

**Body (F)**

Body to be seamless molded fiberglass (F.R.P.) with smooth exterior surfaces and rounded corners. To be constructed by a hand lay-up process with four layers of 1.5 oz continuous strand fiberglass mat, plus a 24 oz layer of woven roving on the bottom for added strength. Fiberglass to be flame retardant per specification ASTM E-162 having a flame spread of 25% or less. Body interior to be reinforced at each end with 4 wide, 12 gauge galvanized channels welded to form integral U frame for maximum stress relief.

**Top**

Top to be 30" wide and fabricated from 14 ga. stainless steel with square turndown on all sides and corners fully welded, ground and polished. Top to have #4 satin finish and all edges having #7 hi-lite finish.

**Refrigerated Dispenser**

Unit shall have a welded stainless steel watertight interior liner with 2" of urethane foam insulation and full perimeter breaker strips at the top. 1" brass drain shall extend to a shut off valve below the fiberglass body. Refrigerated temperature to be maintained at 38 F, (refrigerated section) and -10 F (freezer section) by a forced-air blower coil and an expansion valve system. Freezer section to include an installed condensate evaporator. Openings will be fitted high impact plastic throat liner and hinged insulated stainless steel lids.

Each opening shall contain a stainless steel self-leveling dispenser. Dispensing mechanism shall be constructed with automatic self-leveling elevators, enclosed in a stainless steel housing. The lowerator mechanisms shall be field adjustable without the use of tools and be connected

to a removable heavy gauge stainless steel carrier. Each compartment to be furnished with six (6) removable divider trays.

**Compressor Housing**

Cross flow ventilated compartment to have two stainless steel exterior frames complete with removable stainless steel louvers.

**Condensing Unit**

Unit to contain a fully hermetic system using R-507 refrigerant, with all necessary controls for proper operation. System to be hooked-up, tested in the factory and made ready to plug in on the job.

**Casters**

5" diameter, ball bearing, swivel type casters to be non-marking and with brakes on all wheels. Casters are mounted with exterior and interior bracing for maximum stress relief.

We reserve the right to change specifications and product design without notice. Such revisions do not entitle the buyer to corresponding changes, improvements, additions or replacement for previously purchased equipment.

All equipment to be built in accordance with the Underwriters Laboratories, Inc. and the National Sanitation Foundation, Inc. standards and shall bear the Underwriters Laboratories, Inc. listing label for safety and the Underwriters Laboratories classification label for sanitation.