

Solid Top 90° Wedge Filler Unit

Stainless Steel (S) or Laminate Panel (L)

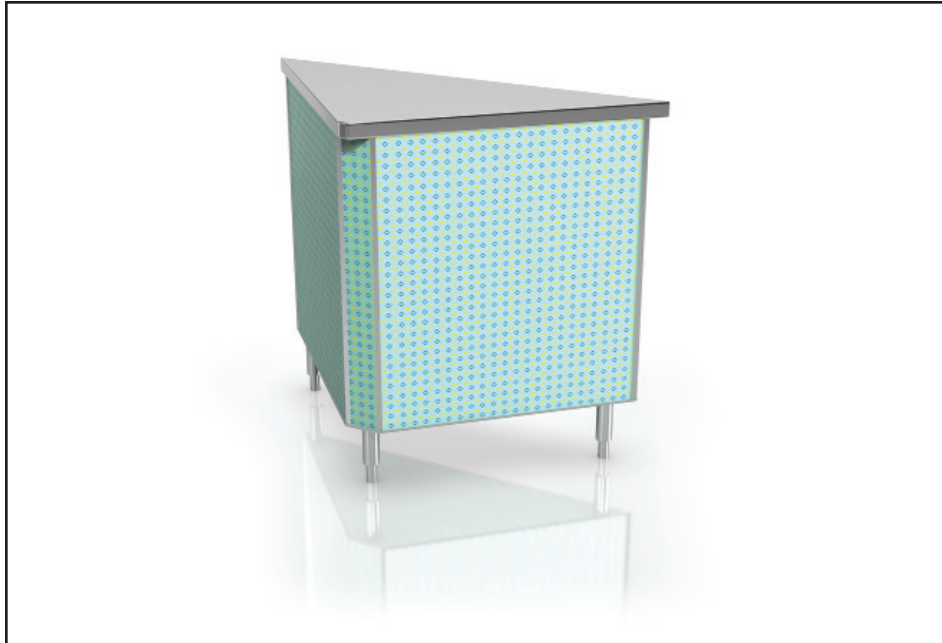

ST-W-90-L shown with option: (SS) Stainless Steel Legs

Project: _____

Item: _____

Quantity: _____

Date: _____

Models

ST-W-90-L/S

Standard Features

- ✓ 14 gauge stainless steel top
- ✓ 5" Locking Swivel Casters

Top Options

- Height other than standard 36" (specify _____)
- (CT) Corian® Top (specify _____)
- (QT) Stone Top (specify _____)
- (AA) Cam Operated Line-up Lock
- (FF) End Drop Shelf
- Cutouts (specify _____)

Tray Slide/Cutting Board Options

- (A) Beaded, stainless steel tray slide
- (B) Flat Surface, stainless steel tray slide
- (C) Tubular stainless steel tray slide
- (CTS) Corian® Tray Slide (specify _____)
- (QTS) Stone Tray Slide (specify _____)
- Powder Coated brackets (specify RAL # _____)
- (D) 8" wide Stainless Steel cutting board
- (E) 8" wide Richlite® composite cutting board
- Other cutting board width (specify _____)

Base Options

- (AA) Cam Operated Line-up Locks
- (MM) Vertical Trim Strips
- (SS) Stainless Steel Legs
- S/S Toe Kick
- Other _____

Electrical Options

- (DD) Convenience outlet, flush
- (EE) Convenience outlet, pedestal
- (DC) Daisy chain
- (LC) Load center

Other Options (Contact Factory)

- Vinyl Graphic Wrap
- Body Decal
- Over-structure with signage & lights (specify _____)
- Digital Menu Boards
- Progressions Décor Panel

- ▶ Upgrade directional flow in serving lines
- ▶ Makes a perfect 90° turn in any serving line
- ▶ Sanitary, easy to clean de-sign

Solid Top 90° Wedge Filler Unit

Stainless Steel (S) or Laminate Panel (L)

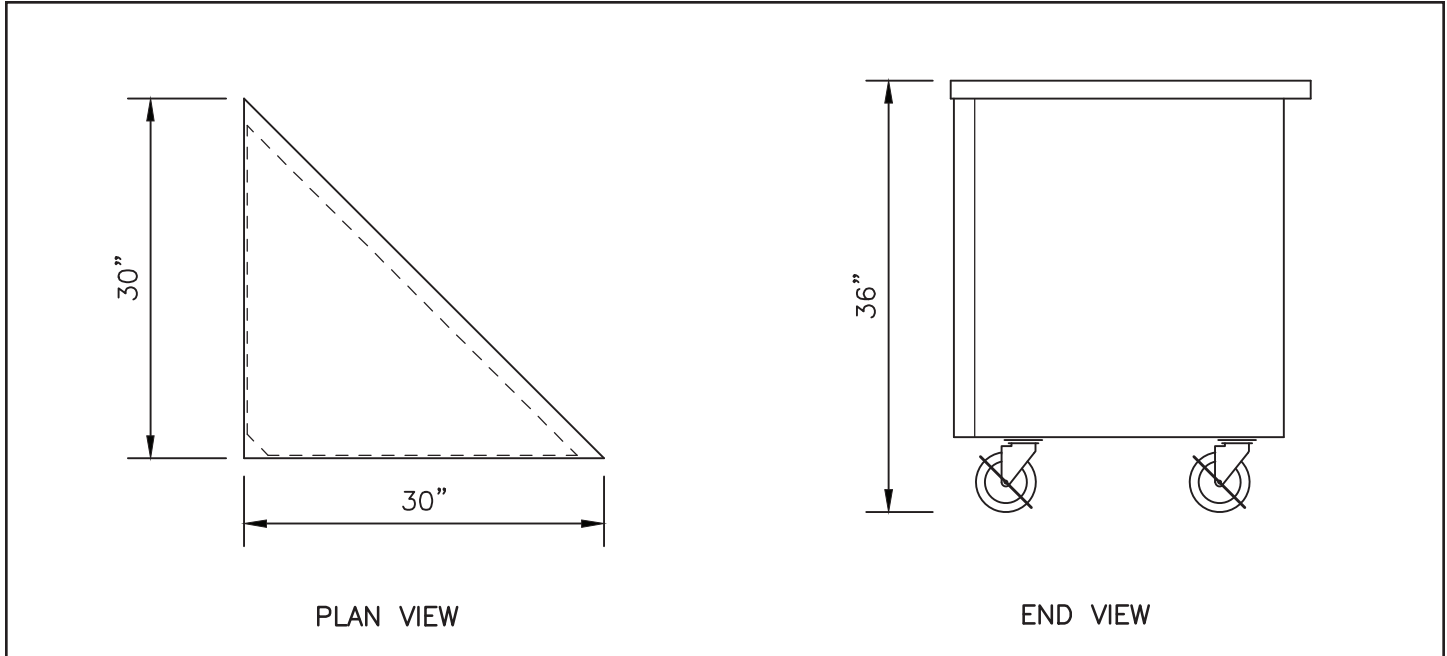

Model	L x W x H	Approx. Ship Weight
ST-W-90	30" x 30" x 36"	225 lbs.

Top

Top to be 30" wide and fabricated from a minimum of 14 ga. stainless steel with square turndown on all sides and corners fully welded, ground and polished. Top to have #4 satin finish and with all edges having a #7 hi-lite finish.

Body (S)

Uni-body structure, fabricated from 18 gauge stainless steel, welded ground and polished. Interior reinforced with 12 gauge galvanized uprights to support shelving and a 20 gauge steel bottom.

Body (L)

Standard grade laminate to cover all sides of an 18 gauge steel uni-body structure. Interior reinforced with 12 gauge galvanized uprights to support shelving and a 20 gauge steel bottom. Corners and bottom edge provided with 1/2" stainless steel trim strips.

Casters

5" diameter, ball bearing, swivel type casters to be non-marking and with brakes on all wheels. Casters to be mounted thru two 12 gauge channels for extra rigidity.

We reserve the right to change specifications and product design without notice. Such revisions do not entitle the buyer to corresponding changes, improvements, additions or replacement for previously purchased equipment.

All equipment to be built in accordance with the Underwriters Laboratories, Inc. and the National Sanitation Foundation, Inc. standards and shall bear the Underwriters Laboratories, Inc. listing label for safety and the Underwriters Laboratories classification label for sanitation.