

ISSUE DATE: 4/98

**OPERATIONS AND MAINTENANCE MANUAL  
REPLACEMENT PARTS LIST  
FOR:**



**COLORPOINT**  
DIVISION OF LOW TEMP INDUSTRIES, INC.

9192 TARA BOULEVARD P.O. BOX 795 JONESBORO, GEORGIA 30237  
TELEPHONE: (770) 478-8803

**FIBERGLASS SERVING EQUIPMENT**

# ATTENTION KITCHEN MANAGER

## IMPORTANT TECHNICAL NOTICE REFRIGERATION AIR FILTERS

All self contained refrigeration systems provided by Low Temp Industries are provided with a 10" x 10" x 1" air filter located at the face of the condenser directly behind the louver panel. It is important to check this filter every 30 days and replace if necessary to ensure the proper operation of the unit. Failure to check this filter and replace if clogged can and will cause premature compressor failure and will not be covered by factory warranty.

If construction is not complete when the equipment is started be sure that the filters are checked and replaced if necessary once the final clean up is completed.

The purpose for this filter is to keep the condenser fins as clean as possible. If the filter is removed and discarded the fins will become clogged and will require a chemical rinse to clear them. When the condenser fins become clogged or the filter is not checked and replaced the compressor work harder to maintain temperature and the box interior cabinet temperature will rise.

It is **very important** that the MAINTENANCE PERSONNEL be informed of this feature provided on our equipment. Your cooperation in maintaining this feature is greatly appreciated. If you have any questions or problems concerning this matter please contact Casey Hammonds or Ben Shackelford in the Low Temp Engineering Department 770-478-8803

## CONDENSER FILTER ACCESS CHANGE EVERY 30 DAYS

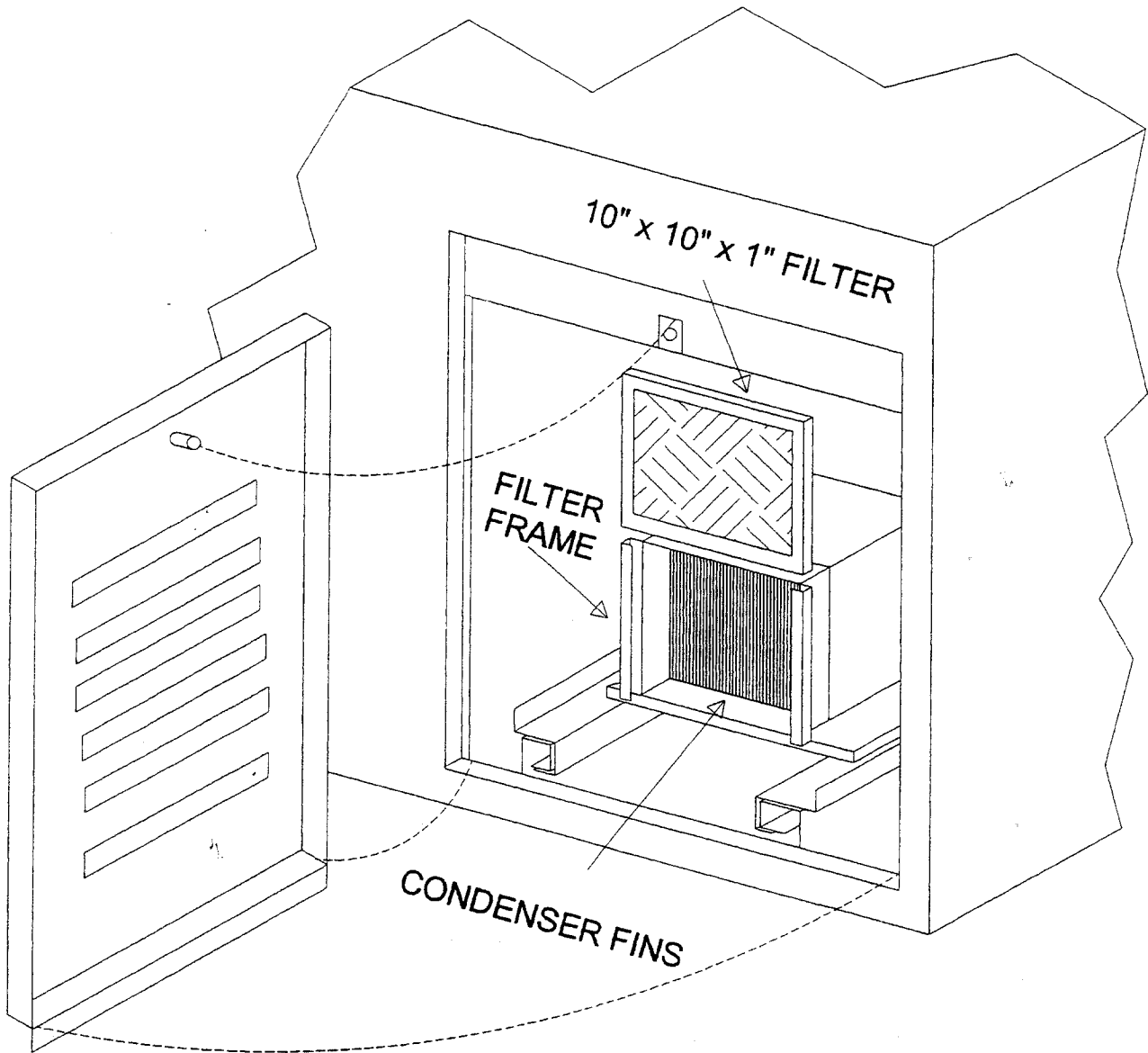

1. TO REMOVE THE LOUVERED PANEL LOOSEN THE THUMB SCREW LOCATED AT THE TOP OF THE PANEL.
2. TILT THE TOP OUT AND LIFT THE PANEL STRAIGHT UP.
3. LIFT THE FILTER STRIAIGHT UP OUT OF THE TRACK.
4. WHEN REPLACING THE FILTER NOTE THE AIR FLOW DIRECTION. IT SHOULD BE POINTING TOWARD THE CONDENSER FINS.

**CAUTION:** THIS FILTER MUST BE CHANGED EVERY 30 DAYS TO ENSURE PROPER OPERATION OF THE UNIT. FAILURE TO CHANGE THE FILTER WILL CAUSE THE COMPRESSOR TO RUN HOT AND CAUSE PREMATURE COMPRESSOR FAILURE. IF THE FILTER IS REMOVED AND NOT REPLACED THE CONDENSER FINS WILL BECOME CLOGGED AND REQUIRE A CHEMICAL RINSE TO CLEAR .

\*\*\*\*\* INSPECTION \*\*\*\*\*

UPON RECEIPT, THE CRATE SHOULD BE INSPECTED FOR VISUAL DAMAGE. ANY DAMAGE SHOULD BE REPORTED IMMEDIATELY TO THE CARRIER.

\*\*\*\*\* INSTALLATION INSTRUCTIONS \*\*\*\*\*

THE COLORPOINT CTAD- SERIES REFRIGERATED MILK AND ICE CREAM DISPENSER IS A SELF CONTAINED UNIT FOR DISPENSING MILK AND ICE CREAM. THIS UNIT IS DESIGNED TO HOLD MILK DURING A NORMAL SERVING PERIOD AT A MAXIMUM OF 40 DEGREES FAHRENHEIT AND ICE CREAM DURING A NORMAL SERVING PERIOD AT A MAXIMUM OF -5 DEGREES FAHRENHEIT. THE DESIGN OF THIS UNIT ALLOWS FOR A MODULAR OPERATION, WHERE A GROUP OF UNITS CAN BE ARRANGED TO FORM A CAFETERIA SERVING LINE. ROLL THE TABLE INTO A SERVING LINE OR OTHER NEEDED POSITION AND LOCK THE BRAKES ON THE CASTERS.

IF LINE UP LOCKS ARE PROVIDED, SIMPLY ALIGN THE UNITS AND PUSH THE BARREL BOLTS THROUGH THE KEY HOLE SLOTS ON BOTH UNITS THEN TURN THE BOLT DOWN AND PUSH UP THE CAM LOCKING LEVER. TO UNLOCK THE UNITS, REVERSE THIS PROCEDURE.

\*\*\*\*\* OPERATING INSTRUCTIONS \*\*\*\*\*

**START UP:**

THE REFRIGERATION SYSTEM SUPPLIED WITH THE REFRIGERATED MILK AND ICE CREAM DISPENSER IS OF THE HERMETIC TYPE. REFRIGERANT IS METERED BY EXPANSION VALVES WHICH ARE LOCATED IN THE BLOWER COIL. EACH REFRIGERATED MILK AND ICE CREAM DISPENSER IS SELF CONTAINED AND HAS BEEN LEAK TESTED, CHARGED WITH REFRIGERANT AND OPERATED TO ENSURE THE PROPER OPERATION AND SETTING OF THE CONTROLS.

ENERGIZE THE UNIT BY ATTACHING THE PLUG TO AN APPROPRIATE ELECTRICAL SUPPLY (115 VAC, 60 HZ, SINGLE PHASE, 12 AMP), **SET THE DEFROST TIMER TO THE PROPER TIME OF DAY** AND TURNING ON THE SERVICE SWITCH LOCATED IN THE COMPRESSOR COMPARTMENT THE GREEN INDICATOR LIGHT SHOULD BE ON. AFTER APPROXIMATELY TWENTY-FOUR HOURS OF OPERATION THE UNIT WILL BE READY FOR USE.

**OPERATION:**

THE TEMPERATURE INSIDE EACH COMPARTMENT IS REGULATED BY A THERMOSTAT WHICH IS LOCATED INSIDE EACH BLOWER COIL WITH AN ACCESSIBLE CONTROL KNOB. THE UNITS ARE **PRE SET AND TESTED AT THE FACTORY** BEFORE THE SYSTEM IS SHIPPED. AT INITIAL THE UNIT SHOULD BE OPERATED FOR **TWENTY FOUR (24) HOURS** BEFORE ANY ADJUSTMENTS ARE ATTEMPTED. CARE SHOULD BE TAKEN WHEN ADJUSTING THESE THERMOSTATS. ONCE AN ADJUSTMENT HAS BEEN MADE CLOSE THE BOX AND WAIT **THIRTY (30) TO FOURTY-FIVE (45) MINUTES** BEFORE MAKING ANY FURTHER ADJUSTMENTS.

THE LOW PRESSURE CONTROL (PHYSICALLY LOCATED IN THE FRONT OF THE COMPRESSOR COMPARTMENT) CONTROLS THE COMPRESSOR. WHEN THE THERMOSTATS LOCATED IN THE BLOWER COILS ARE SATISFIED THEY CLOSE A LIQUID LINE SOLENOID ALSO LOCATED IN THE UNIT COOLER. THIS CAUSES THE COMPRESSOR TO PUMP DOWN AND CYCLE OFF. THE CUT IN IS SET AT THE FACTORY AT +30 PSI AND THE DIFFERENTIAL IS SET AT 25.

**NOTE: THIS SYSTEM IS PROVIDED WITH AN AUTOMATIC ELECTRIC DEFROST. THE DEFROST IS CONTROLLED BY A TIME CLOCK LOCATED INSIDE THE COMPRESSOR HOUSING. THIS CLOCK MUST BE SET TO THE PROPER TIME OF DAY WHEN THE SYSTEM IS PLUGGED IN AND RESET IF THE POWER IS REMOVED FROM THE SYSTEM. THE FACTORY RECOMMENDS THREE (3) TWENTY MINUTE DEFROST CYCLES SPACED DURING NON-PEAK PERIODS. WHEN THE RED INDICATOR LIGHT LOCATED AT THE COMPRESSOR HOUSING INDICATES THAT THE SYSTEM IS IN DEFROST. THE TEMPERATURE INDICATING DEVICE WILL RISE ABOVE THE DESIRED TEMPERATURE DURING THIS CYCLE BUT THE UNIT WILL RECOVER WITHIN TWENTY (20) TO THIRTY (30) MINUTES AFTER THE DEFROST HAS TERMINATED. THIS WILL NOT AFFECT THE PRODUCT TEMPERATURE.**

## **CLEANING:**

THE OUTSIDE OF THIS UNIT IS FABRICATED FROM FIBERGLASS AND SHOULD BE CLEANED WITH A MILD NON-ABRASIVE CLEANER. NORMAL LOTION SOAP THAT IS USED IN SINKS IS SATISFACTORY.

THE INNER LINER OF THIS UNIT IS FABRICATED OF 304 STAINLESS STEEL. PLEASE SEE "HOW TO CLEAN STAINLESS STEEL" IN THIS MANUAL. NOTE THAT THIS IS A VERY BROAD SECTION ON CLEANING AND THE TYPE OF EQUIPMENT AND END USE SHOULD BE KEPT IN CONSIDERATION BEFORE SELECTING ANY SPECIAL CLEANERS.

## **ELECTRICAL SYSTEM:**

### **\*\*\*\*\* WARNING \*\*\*\*\***

IN ORDER TO PREVENT ANY ELECTRICAL ACCIDENTS, THIS DISPENSER SHOULD BE INSTALLED AND SERVICED BY QUALIFIED MAINTENANCE PERSONNEL ONLY PER NATIONAL ELECTRICAL CODE STANDARDS.

### **\*\*\*\*\* WARNING \*\*\*\*\***

INDIVIDUAL BREAKERS OR FUSES SHOULD BE PROVIDED FOR EACH COMPRESSOR, MOTOR. GROUP FUSING, WHERE TWO OR MORE COMPRESSORS ARE INSTALLED ON ONE FUSE OR BREAKER IS **\*\*NOT RECOMMENDED\*\***. REFER TO THE NATIONAL ELECTRICAL CODE FOR APPROPRIATE LINE FUSE OR BREAKER SIZE.

## **HOW TO CLEAN STAINLESS STEEL**

THE FOLLOWING INFORMATION WAS TAKEN FROM A PAMPHLET BY MR. RICHARD E. PARET, STAINLESS STEEL SPECIALIST, AMERICAN IRON AND STEEL INSTITUTE.

STAINLESS STEEL IS ONE OF THE EASIEST MATERIALS TO CLEAN AND KEEP CLEAN.

THE REASONS FOR STAINLESS STEEL'S EASE OF CLEANING ARE EASY TO SEE; THEY LIE IN THE NATURE OF THE METAL ITSELF.

1. IT'S HARD, TOUGH SURFACE. STAINLESS STEEL WILL WORK HARDEN, THAT IS, THE MORE IT IS USED, THE MORE RESISTANT TO WEAR IT BECOMES. STAINLESS STEEL WILL NOT DEVELOP ROUGH SPOTS THAT HARBOR BACTERIA AND SOIL.
2. HIGH CORROSIVE RESISTANCE. STAINLESS STEEL IS PRACTICALLY UNTOUCHED BY THE CORROSIVE ATTACKS OF MOISTURE, DETERGENTS, FOOD ACIDS, BLOOD SALTS AND OTHER CORRODENTS CONNECTED WITH FOOD PREPARATION. THIS MEANS THAT STAINLESS STEEL ALWAYS HAS A BRIGHT SURFACE FREE FROM OXIDES THAT CAN AFFECT THE FLAVOR OF FOODS.

THE SECRET OF MAINTAINING STAINLESS STEEL IS FREQUENT, SCHEDULED CLEANING THAT WILL PREVENT BUILD UP OF SURFACE DEPOSITS. SURFACE DEPOSITS, IF ALLOWED TO REMAIN FOR LONG PERIODS OF TIME CAN HARM STAINLESS STEEL. STAINLESS STEEL THRIVES ON EXPOSURE TO AIR; UNDER CERTAIN CONDITIONS, THE LENGTHY DEPRIVATION OF OXYGEN BY HEAVY SOIL DEPOSITS CAN CAUSE LOCALIZED PITTING OR STAINING.

NEGLECTING THE MATERIAL IN THIS MANNER IS **DEFINITE ABUSE** WHICH EVEN STAINLESS STEEL IS NOT IMMUNE.

## HOW TO CLEAN STAINLESS STEEL (CONT.)

TWO BASIC RULES:

1. CLEAN FREQUENTLY, AND ON A FIXED SCHEDULE.
2. SELECT THE SIMPLEST METHOD.

TO REMOVE ORDINARY DIRT AND FOOD RESIDUE FROM STAINLESS STEEL EQUIPMENT THAT OPERATES AT LOW TEMPERATURES, USE ORDINARY SOAP AND WATER AND APPLY WITH A SPONGE, FIBER BRUSH OR CLOTH. TO HASTEN ACTION, ADD EITHER SODA ASH, BAKING SODA, BORAX OR ANY OF SEVERAL NON-ABRASIVE COMMERCIAL CLEANSING AGENTS.

TO REMOVE SPLATTER OR CONDENSED VAPOR WHICH HAVE "BAKED" ONTO THE EQUIPMENT, THE TREATMENT OUTLINED ABOVE IS OFTEN SUFFICIENT. IN OTHER CASES A GENTLE TO VIGOROUS POLISHING ACTION MAY BE NECESSARY.

FIRST TRY A PASTE MADE WITH WATER AND AMMONIA AS THE LIQUID AND EITHER MAGNESIUM OXIDE, FINELY POWDER PUMICE OR FRENCH CHALK AS THE SOLID. YOU CAN ALSO USE ONE OF SEVERAL COMMERCIAL CLEANERS LISTED IN THE FOLLOWING TABLE.

RUB AS GENTLY AS POSSIBLE IN THE DIRECTION OF THE POLISHING MARKS ON THE STEEL, USING A SOFT CLOTH. FOR MORE RESISTANT DEPOSITS, USE A STAINLESS STEEL SCOURING SPONGE OR STAINLESS STEEL WOOL OF THE FINEST POSSIBLE TEXTURE.

### WHAT NOT TO DO:

DO NOT USE COMMON STEEL WOOL, SCOURING PADS, SCRAPERS, WIRE BRUSHES, FILES OR OTHER STEEL TOOLS, SINCE THESE CAN MAR THE STAINLESS STEEL. THESE PARTICLES WILL EVENTUALLY RUST AND STAIN THE SURFACE, AND YOU MAY HAVE TO REFINISH IT.

SLIGHTLY DARKENED AREAS SOMETIMES APPEAR ON STAINLESS STEEL SURFACES WHERE HEAT HAS BEEN APPLIED DURING FABRICATION OR IN SERVICE.

THESE ARE CAUSED BY THICKENING OF THE PROTECTIVE SURFACE OF STAINLESS STEEL, AND ARE NOT HARMFUL. REMOVAL CALLS FOR ENERGETIC SCOURING, AGAIN USING A STAINLESS STEEL WOOL OR SCOURING PAD, COMBINED WITH A SCOURING POWDER OR ONE OF THE HEAT-TINT REMOVERS LISTED IN THE TABLE.

THREE RULES WILL PREVENT HEAT TINTING:

- 1) USE ONLY ENOUGH HEAT TO DO THE JOB EFFICIENTLY.
- 2) DO NOT APPLY HEAT TO EMPTY EQUIPMENT.
- 3) AVOID CONCENTRATING HEAT ON A SMALL AREA.

### CAUTION IS ADVISED

IN STERILIZING STAINLESS STEEL EQUIPMENT, PAY PARTICULAR ATTENTION TO AGENTS CONTAINING CHLORINE COMPOUNDS SUCH AS POTASSIUM HYPOCHLORITE. THESE COMPOUNDS MAY BREAK DOWN AND RELEASE FREE CHLORINE, OR HYDROLYZE TO FORM HYDROCHLORIC ACID.

STAINLESS STEEL RESISTS ATTACK BY SUCH COMPOUNDS FOR UP TO TWO HOURS. SEVERE LOCALIZED PITTING MAY OCCUR FROM LONGER EXPOSURE. FOR SAFE USE OF THESE AGENTS, KEEP CONTACT TIME SHORT, FLUSH THOROUGHLY WITH WATER, AND OPERATE EQUIPMENT NORMALLY BETWEEN APPLICATIONS. USING THESE PRECAUTIONS, THE STERILIZATION PROCESS CAN BE REPEATED ANY NUMBER OF TIMES.

## CLEANERS AND THEIR EFFECT ON STAINLESS STEEL

<u>Cleaning agent</u>	<u>Method of Application</u>	<u>Effect on finish</u>
<b>1. Tightly adhering deposits of "baked on" spatter, oil, grease, weather stain, dyes or other light discoloration may be removed with any of the following cleaners.</b>		
Grade FFF Italian pumice whiting or bon ami	scour or rub with damp cloth	satisfactory for all finishes use light pressure on no.7
Liquid NuSteel	scour with small amount on dry cloth	satisfactory for all finishes if rubbing pressure is light
Paste NuSteel or Temp	scour with small amount on dry cloth	satisfactory for no. 4 finish. Will scratch no.7
House hold cleaners such as Old Dutch, Sunbrite, Wyandotte, Bob-O, Gold Dust and Sapolio	Rub with damp cloth	Will scratch no. 4 finish slightly
Grade F Italian Pumice	Rub with damp cloth	Will scratch no.4 finish slightly
Cooper's stainless steel polish	Rub with damp cloth	satisfactory for no.4 finish
Allen stainless steel polish	Rub with damp cloth	Scratches considerably but leaves mirror reflection
Best Effect Chemical Co. cleaner & Passivator	Rub with damp cloth	May scratch no.4 finish slightly
<b>2. Heat tint or heavy discoloration with the following (see notes below)</b>		
Allen stainless polish	Small amount on damp cloth	Excellent heat tint remover
Birdsall's "Staybright"	Rub with damp cloth	Very good for heat tint removal. Does not scratch no.4finish but does scratch no.7
Wyandotte or Bob-O	Rub with damp cloth	Good for heat tint removal
Oxalic acid (use warm) Or 15% nitric acid	Swab or immerse. Always follow with a 5% sodium carbonate or neutralizer rinse	Good discoloration remover
Best Effect Chemical Co. cleaner & Passivator	Rub with damp cloth	May scratch no 4 but leaves clean surface

**CLEANERS AND THEIR EFFECT ON  
STAINLESS STEEL  
(Cont.)**

Cleaning agent	Method of Application	Effect on Finish
3. The following detergents and solvents are excellent removers of grease, oil and fatty acids, where swabbing or rubbing is not practical.		
4 to 6% solution of (sodium Metasilicate) (Trisodium Phosphate) (Sodium Metaphosphate) (Sodium Pyrophosphate)		All excellent removers of grease, oil, and milkstone
5-15% caustic soda (hot or cold)		Will remove grease and milkstone
4. The following organic solvents may be used for removing oils and grease deposits:		
Carbon-tetrachloride, Naphtha, Trichlorethylene Acetone, Kerosene, Gasoline, Ether, Alcohol, Benzene		No affect on finish However, take all precautions against fire.

**Notes:** ordinary wool or steel brushes should never be used on stainless steel surfaces. Particles of steel may become imbedded in the stainless steel surface, and rusting of these particles will eventually appear as stains. Use stainless steel wool or sponge on stainless steel equipment. Heat tint removers will usually scratch stainless steel surfaces. This, however, is necessary in removing heat tint by hand. Oakite, a fibrous material, may be used in place of metal sponges or cloth pads for applying cleaners and polishes. This material is effective in aiding in removal of milkstone.

For heavy hard water deposits, 15-20% (by volume) nitric acid is very effective. Acid treatment should be followed by a thorough water rinse.

The action of soldering fluxes should be neutralized immediately with a 5% sodium carbonate solution.

Soap and water followed by a water rinse will not harm stainless steel.



## Preventative Maintenance of COLORPOINT Equipment

*To insure that your equipment will continue to operate properly, please follow these simple steps:*

- #1** Make sure that the **FILTER** in the louvered panel is always kept clean of dust and dirt. Failure to do this will cause compressor to overheat and may cause compressor failure, and will also **VOID ANY FACTORY WARRANTY** on compressor.
- #2** **MODELS CTAM, CTAL, CTAD AND CPM-FD.** To insure proper operation of these units, periodically check the evaporator unit coolers to ensure that the air intakes and the discharge areas are kept clean and clear. If the air fan intakes or discharge become blocked with wrappings or debris this will cause the coils located inside the unit coolers to freeze and the temperature in the unit will rise.
- #3** **MODELS CTAL AND CTAD.** To insure proper operation the defrost timers must be set properly. The factory recommends three (3) twenty (20) minute defrost cycles. These should be set for low peak periods. During defrost cycle the temperature indicating device will rise above the freezing point. This is normal for this system. The product temperature will not be adversely affected because this system will recover to the proper operational temperature within 15 to 30 minutes. Note: the system is provided with a two (2) indicator lights. The Green indicator shows that power switch to the system is on. The Red indicator shows that the system is in defrost. Make sure that the system has completed its defrost cycle and has proper time to recover before entering a service call. If these defrost cycles are not set properly this unit will not perform properly. An additional defrost cycle may be required if you are in a HIGH humidity environment.
- #4** **MODELS CFM, CFT AND CTAM.** Factory recommends that these units be defrosted at least once a day. Also, refer to step #1.
- #5** **MODEL CPT-R.** Refer to steps #1, and step #4
- #6** **MODELS CTAM.** When cleaning these units is important to remove the power to the circulation fan and remove it from the unit. If the fan unit becomes wet, dry the fan assembly before applying power.

For more cleaning information on these models, see the section on "CLEANING" in this manual.

## REFRIGERATION SERVICE CHART

<u>COMPLAINT</u>	<u>PROBLEM</u>	<u>SOLUTION</u>
A. COMPRESSOR WILL NOT START	1. LINE DISCONNECT SWITCH OPEN 2. FUSE REMOVED OR BLOWN 3. CONTROL STUCK IN OPEN POSITION 4. CONTROL OFF DUE TO COLD LOCATION	1. CLOSE START OR DISCONNECT SWITCH 2. REPLACE FUSE 3. REPAIR OR REPLACE CONTROL 4. RELOCATE CONTROL
B. COMPRESSOR WILL NOT START, HUMS BUT TRIPS OVERLOAD PROTECTOR	1. LOW VOLTAGE TO UNIT 2. STARTING CAPACITOR DEFECTIVE 3. RELAY FAILING TO CLOSE 4. COMPRESSOR MOTOR HAS A WINDING OPEN OR SHORTED 5. INTERNAL MECHANICAL TROUBLE IN COMPRESSOR	1. CALL POWER SUPPLIER 2. REPLACE CAPACITOR 3. REPLACE RELAY 4. REPLACE COMPRESSOR 5. REPLACE COMPRESSOR
C. COMPRESSOR STARTS BUT DOES NOT SWITCH OFF OF START WINDING	1. LOW VOLTAGE TO UNIT 2. RELAY FAILING TO OPEN 3. RUN CAPACITOR DEFECTIVE 4. EXCESSIVELY HIGH DISCHARGE 5. COMPRESSOR MOTOR HAS A WINDING OPEN OR SHORTED 6. INTERNAL MECHANICAL TROUBLE IN COMPRESSOR	1. CALL POWER SUPPLIER 2. REPLACE RELAY 3. REPLACE CAPACITOR 4. CHECK DISCHARGE SHUT OVERCHARGE OR INSUFFICIENT COOLING CONDENSER. 5. REPLACE COMPRESSOR 6. REPLACE COMPRESSOR
D. COMPRESSOR STARTS AND RUNS, BUT SHORT CYCLES ON OVERLOAD PROTECTOR	1. LOW VOLTAGE TO UNIT 2. OVERLOAD PROTECTOR DEFECTIVE 3. RUN CAPACITOR DEFECTIVE 4. EXCESSIVE DISCHARGE PRESSURE 5. COMPRESSOR TOO HOT, RETURN GAS HOT 6. COMPRESSOR MOTOR HAS A WINDING SOUND	1. CALL POWER SUPPLIER 2. CHECK CURRENT, REPLACE PROTECTOR 3. REPLACE CAPACITOR 4. CHECK VENTILATION, RESTRICTIONS IN COOLING MEDIUM, RESTRICTIONS IN REFRIGERANT SYSTEM 5. CHECK REFRIGERANT CHARGE (FIX LEAK IF NECESSARY) 6. REPLACE COMPRESSOR
E. UNITS RUNS OK, BUT SHORT CYCLES ON	1. OVERLOAD PROTECTOR 2. THERMOSTAT 3. HIGH PRESSURE CUT OUT DUE TO: A. INSUFFICIENT AIR B. OVERCHARGE C. AIR IN SYSTEM 4. LOW PRESSURE CUT-OUT DUE TO:	1. SEE D-2 ABOVE 2. DIFFERENTIAL SET TOO CLOSE, WIDEN 3A. CHECK AIR SUPPLY TO CONDENSER 3B. REDUCE REFRIGERANT CHARGE 3C. PURGE

## REFRIGERANT SERVICE CHART (CONT.)

<u>COMPLAINT</u>	<u>PROBLEM</u>	<u>SOLUTION</u>
	A. UNDERCHARGED	4A. FIX LEAK-AND ADD REFRIGERANT
	B. EXPANSION VALVE OUT OF ADJUSTMENT.	4B. RE-ADJUST VALVE
	C. RESTRICTION IN EXPANSION VALVE.	4C. REPLACE VALVE
F. UNIT OPERATES LONG OR CONTINUOUSLY	1. SHORTAGE OF REFRIGERANT	1. FIX LEAK, ADD CHARGE
	2. CONTROL CONTACTS STUCK OR FROZEN CLOSED	2. CLEAN CONTACTS, OR REPLACE CONTROL
	3. REFRIGERANT OR AIR CONDITIONED SPACE HAS EXCESSIVE LOAD OR POOR INSULATION	3. DETERMINE FAULT AND CORRECT CORRECT
	4. EVAPORATOR COIL ICED	4. DEFROST
	5. RESTRICTION IN REFRIGERANT SYSTEM	5. DETERMINE LOCATION AND REMOVE
	6. DIRTY CONDENSER	6. CLEAN CONDENSER
	7. FILTER DIRTY	7. CLEAN OR REPLACE
G. START CAPACITOR OPEN	1. RELAY CONTACTS NOT OPENING PROPERLY	1. CLEAN CONTACTS OR REPLACE IF NECESSARY
	2. PROLONGED OPERATION ON START CYCLE DUE TO: A. LOW VOLTAGE TO UNIT B. IMPROPER RELAY	2A. CALL POWER SUPPLIER 2B. REPLACE
	3. EXCESSIVE SHORT CYCLE	3. DETERMINE REASON FOR SHORT CYCLE (SEE E. AND CORRECT)
H. RUN CAPACITOR OPEN, SHORTED OR BLOWN	1. IMPROPER CAPACITOR	1. DETERMINE CORRECT SIZE AND REPLACE
	2. EXCESSIVELY HIGH LINE VOLTAGE (100% OF RATED-MAX)	2. CALL POWER SUPPLIER
I. SPACE TEMPERATURE TOO HIGH	1. CONTROL SETTING TOO HIGH	1. RESET (CONTROL)
	2. INADEQUATE AIR CIRCULATION	2. IMPROVE AIR MOVEMENT
J. SUCTION LINE FROSTED OR SWEATING	1. EXPANSION VALVE STUCK	1. CLEAN VALVE OF FOREIGN PARTICLES REPLACE IF NECESSARY
	2. EVAPORATOR FAN NOT RUNNING	2. DETERMINE REASON AND CORRECT
	3. OVERCHARGE OF REFRIGERANT	3. CORRECT CHARGE

# COLORPOINT

3-95

BY LOW TEMP INDUSTRIES  
JONESBORO, GEORGIA

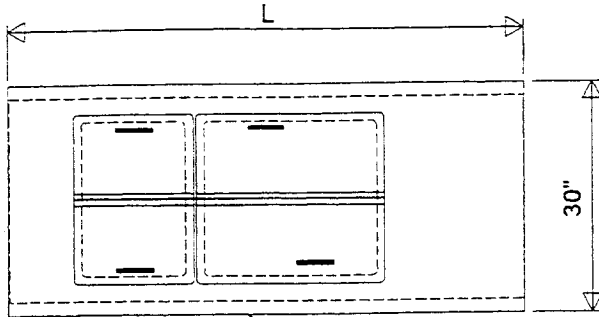

TOP VIEW

## CTAD SERIES FORCED AIR MILK AND ICE CREAM FREEZER

THIS DESIGN MAINTAINS ITS COMPARTMENT TEMPERATURE BY THE USE OF A FAN & FINNED TUBE TYPE EVAPORATOR LOCATED INSIDE THE PRODUCT COMPARTMENT. THIS DESIGN PROVIDES A FASTER PRODUCT PULL DOWN AND RECOVERY THAN THAT PRODUCED BY SIMILAR STATIC COLD WALL DESIGNS.

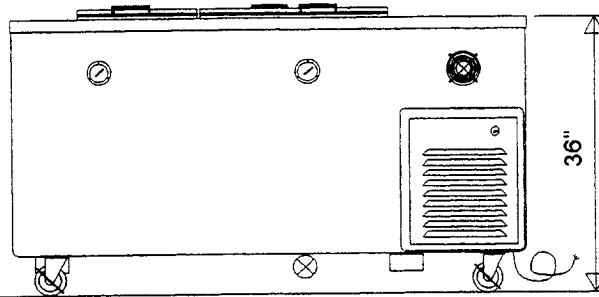

SIDE VIEW

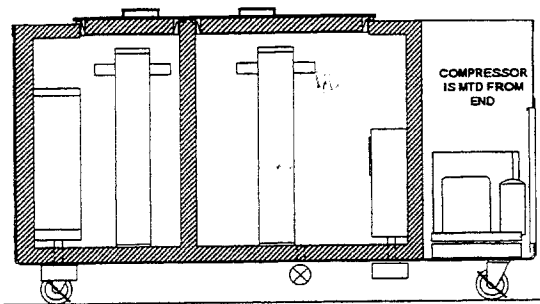

SECTIONAL VIEW

MODEL	L	NO. OF OPENINGS	ICE CREAM CAPACITY 3 OZ. CUPS	MILK CAPACITY 1/2 PT. CTNS	H.P.	VOLTS	AMPS	SHIPPING WT
CTAD-66	66"	(1) 20 X 20 (1) 10 X 20	240	315	1/3	120	11.9	550
CTAD-7	74"	(2) 20 X 20	480	315	1/3	120	11.9	600

TOP: 14 GAUGE STAINLESS STEEL WITH SQUARE TURN DOWNS ON ALL SIDES AND CORNERS FULLY WELDED AND GROUND AND POLISHED TO A #4 SATIN FINISH WITH ALL EDGES HAVING A #7 HI-LITE FINISH.

BODY: SEAMLESS MOLDED FIBERGLASS (F.R.P.) WITH SMOOTH EXTERIOR SURFACE AND ROUNDED CORNERS. ALL FIBERGLASS TO BE FLAME RETARDANT PER SPECIFICATIONS ASTM-E-162 HAVING A FLAME SPREAD OF 25 OR LESS.

PRODUCT COMPARTMENT: TO BE A WATERTIGHT INTERIOR LINER OF STAINLESS STEEL WITH FULL PERIMETER BREAKER STRIP AT THE TOP. AN INTERIOR BOX TEMPERATURE SHALL BE MAINTAINED BY A FORCED AIR, FIN AND TUBE EVAPORATOR SYSTEM WITH AN ACCESSIBLE EXPANSION VALVE AND CAPABLE OF HOLDING A PRODUCT TEMPERATURE OF -10 DEGREES F. EVAPORATOR SHALL HAVE AN AUTOMATIC ELECTRIC DEFROST CONTROLLED BY A 24 HOUR ELECTRO MECHANICAL TIMER. DEFROST MELT WATER SHALL BE PLUMBED TO A CONDENSATE EVAPORATOR ATTACHED TO THE UNDERSIDE OF THE COUNTER.

TOP OPENINGS: SHALL BE FITTED WITH A HIGH IMPACT PLASTIC THROAT LINER AND HINGED INSULATED STAINLESS STEEL LID COVERS. EACH OPENING SHALL CONTAIN TWO (2) REMOVABLE STAINLESS STEEL LOWERATOR MECHANISMS CONNECTED BY A STAINLESS STEEL REMOVABLE PLATFORM. LOWERATOR MECHANISM IS FIELD ADJUSTABLE WITHOUT THE USE OF TOOLS. EACH COMPARTMENT SHALL BE FURNISHED WITH SIX (6) REMOVABLE DIVIDER TRAYS.

COMPRESSOR COMPARTMENT: SHALL HAVE TWO (2) STAINLESS STEEL EXTERIOR FRAMES COMPLETE WITH REMOVABLE LOUVERS TO PROVIDE A POSITIVE CROSS VENTILATION IN THE COMPARTMENT. AN ADDITIONAL AXIAL EXHAUST FAN SHALL BE PROVIDED ON THE DISCHARGE SIDE OF THE COMPARTMENT TO PROVIDED ADDITIONAL VENTILATION.

CONDENSING UNIT: FULLY HERMETIC TYPE R-502 SYSTEM. COMPLETELY PREPIPED WITH ALL NECESSARY CONTROLS FOR PROPER OPERATION. FACTORY TESTED AND MADE READY TO PLUG IN ON JOB SITE. THE CONDENSER (INTAKE SIDE) OF THE CONDENSING UNIT IS PROVIDED WITH A FILTER MEDIA TO HELP PROTECT THE CONDENSER FINS FROM BECOMMING CLOGGED.

CASTERS: 4" DIAMETER BALL BEARING, SWIVEL TYPE, NON MARKING WITH BRAKES ON ALL WHEELS. CASTERS TO BE MOUNTED WITH INTERNAL AND EXTERNAL BRACING FOR MAXIMUM STRESS RELIEF.

APPROVALS: THIS UNIT IS LISTED BY UNDERWRITERS LABORATORIES FOR SAFETY AND CLASSIFIED BY UNDERWRITERS LABORATORIES BY SANITATION UNDER NSF STD.7 AND SHALL BEAR BOTH SEALS.

LOW TEMP INDUSTRIES  
TYPICAL FOLD DOWN BRACKET  
USED FOR BOTH TRAY SLIDES  
AND CUTTING BOARDS

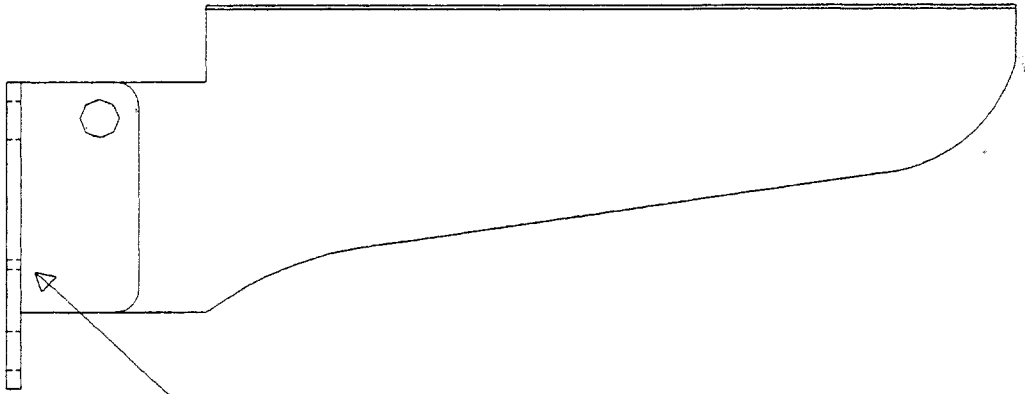

BRACKET LEVEL ADJUSTMENT SCREW  
LOCATED ON HEAL PLATE BETWEEN  
BRACKET SUPPORTS.

NO. 8-32 SET SCREW, REQUIRES A  
2 mm ALLEN WRENCH.

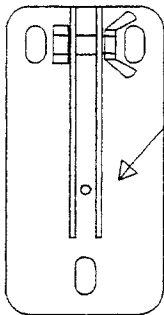

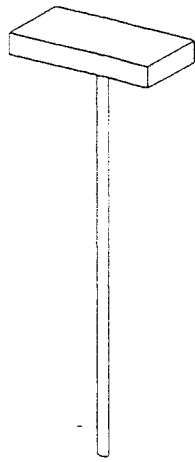

## LOW TEMP INDUSTRIES DISPENSER MECHANISM

THE DISPENSER MECHANISM SHOWN IS USED IN ALL COLORPOINT EQUIPMENT. THIS MECHANISM HAS BEEN ADAPTED FOR MILK AND ICE CREAM DISPENSING AS WELL AS TRAY DISPENSERS. THE DIFFERENCE IN EACH APPLICATION IS THE NUMBER AND TYPE OF SPRINGS USED. THIS EACH MECHANISM CAN HOLD UP TO TWELVE (12) SPRINGS.

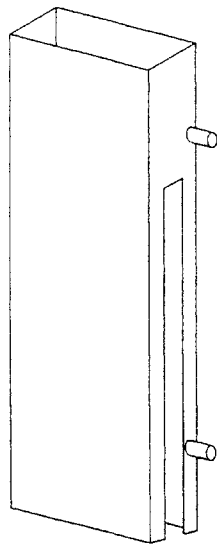

THE TOTAL SYSTEM CONSIST OF TWO (2) MECHANISMS WHICH ARE MOUNTED IN SUPPORT CHANNEL MOUNTED TO THE EQUIPMENT AND A PRODUCT SUPPORT PLATFORM WHICH SPANS THE PRODUCT AREA AND RESTS ON THE FLAT BARS WHICH EXTEND OUT EACH SIDE OF THE DISPENSER HOUSING.

TO REMOVE AND CLEAN THE DISPENSING SYSTEM LIFT THE PRODUCT SUPPORT PLATFORM OFF THE FLAT BAR EXTENSIONS. LIFT EACH DISPENSER UP OUT OF THE SUPPORT CHANNEL. REMOVE THE WING NUT ON THE BOTTOM SIDE OF THE MECHANISM. REMOVE THE BOTTOM CAP AND SLIDE THE INTERNAL SPRING ASSEMBLY OUT. LIFT THE TOP COVER AND GUIDE ROD UP. THE SYSTEM CAN NOW BE PLACED IN A DISHWASHER OR SINK AND CLEANED.

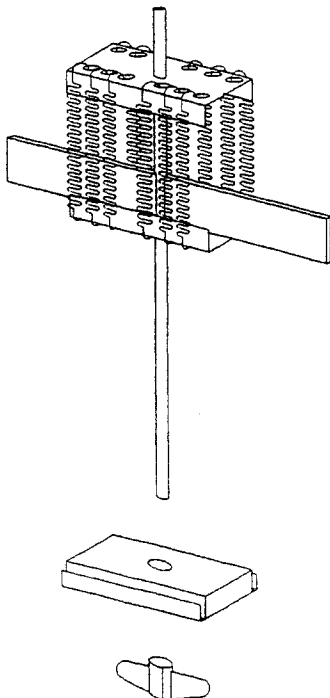

IF TENSION ADJUSTMENTS ARE REQUIRED FOLLOW THE SAME INSTRUCTIONS SHOWN ABOVE TO DISASSEMBLE THE SYSTEM. ADD OR REMOVE SPRINGS AS REQUIRED. LISTED BELOW ARE THE RECOMMENDED SPRING ARRANGEMENTS FOR THIS SYSTEM.

10 X 20 MILK SIX (6) GREEN SPRINGS  
20 X 20 MILK TWELVE (12) GREEN SPRINGS  
10 X 20 ICE CREAM SIX (6) BLUE SPRINGS  
20 X 20 ICE CREAM TWELVE (12) BLUE SPRINGS  
CRATE MILK DISP EIGHT (8) BLUE SPRINGS

TRAY DISPENSING MAY NEED FIELD ADJUSTING  
DUE TO DIFFERENT TYPES AND STYLES OF TRAYS  
STANDARD SPRING ARRANGEMENT IS  
SIX (6) GREEN SPRINGS

# PARAGON MODEL 8045 DEFROST TIMER SET UP INSTRUCTIONS

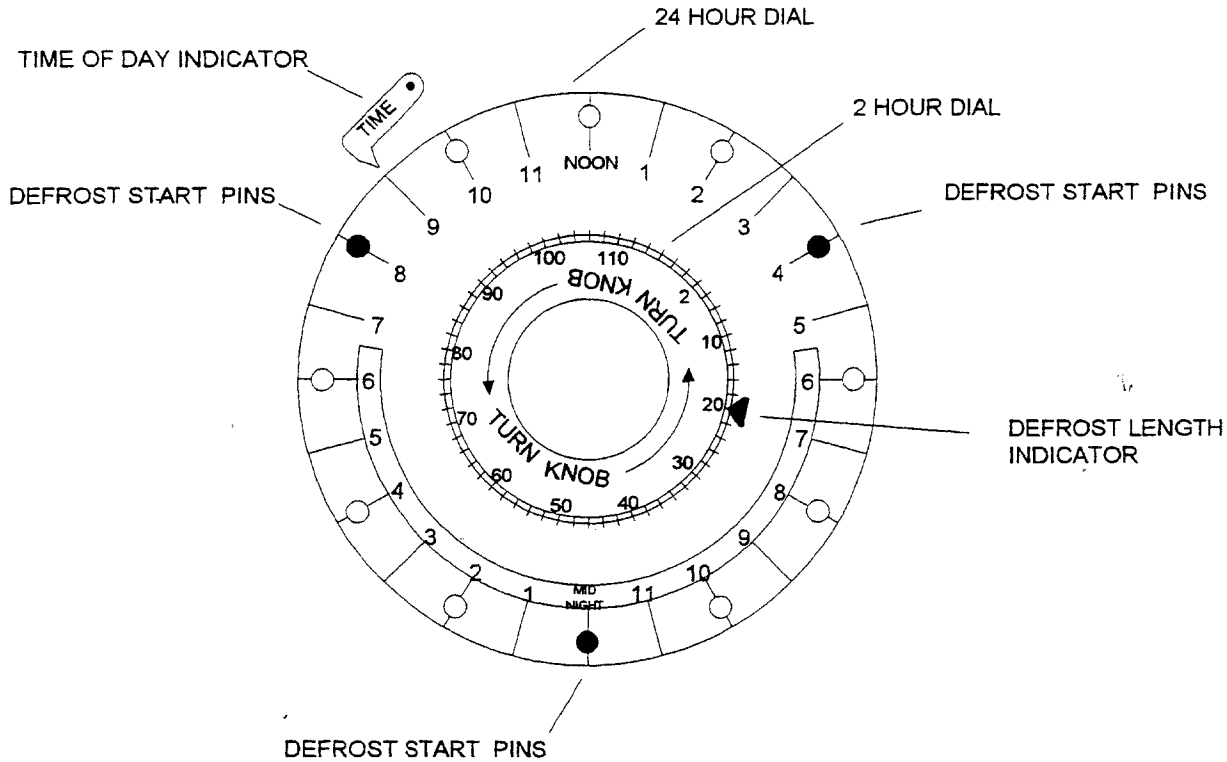

WHEN THE UNIT IS RECEIVED FROM THE FACTORY THE PROPER TIME OF DAY MUST BE SET AFTER THE UNIT HAS BEEN PLUGGED IN.

TO SET THE TIME OF DAY ROTATE THE CENTER KNOB IN THE DIRECTION OF THE ARROWS UNTIL THE PROPER TIME OF DAY ON THE 24 HOUR DIAL IS ALIGNED WITH THE TIME POINTER IN THE UPPER LEFT HAND CORNER. IF THE TIME OF DAY IS NOT PROPERLY SET THE UNIT MAY DEFROST DURING A PEAK PERIOD.

THE UNIT IS SET AT THE FACTORY AS SHOWN ABOVE WITH A DEFROST STARTING AT 8:00 AM, 4:00 PM AND MIDNIGHT. THE LENGTH OF THE DEFROST CYCLE IS TWENTY (20) MINUTES.

TO CHANGE THE DEFROST START TIMES REMOVE THE START PINS BY UNSCREWING THEM FROM THE 24 HOUR DIAL AND REINSTALLING THEM AT ANOTHER TIME. TO CHANGE THE DEFROST LENGTH DEPRESS THE COPPER DEFROST LENGTH INDICATOR AND MOVE TO THE DESIRED TIME.

NOTE! IF THE DEFROST START PINS ARE REMOVED THE UNIT WILL NEVER GO INTO DEFROST. IT IS NOT RECOMMENDED TO HAVE A DEFROST LENGTH GREATER THAN TWENTY (20) MINUTES. IF ADDITIONAL DEFROSTING IS REQUIRED CHANGE THE DEFROST START TIMES TO 2:00 AM, 8:00 AM, 2:00PM AND 8:00 PM.

IF THERE ARE ADDITIONAL QUESTIONS CONCERNING THE DEFROST SETTINGS CALL THE ENGINEERING DEPARTMENT AT LOW TEMP INDUSTRIES.

**REPLACEMENT PARTS LIST  
MODELS CTAD-5, CTAD-66 AND CTAD-7**

**(THIS SYSTEM USES R-507 REFRIGERANT)**

<b>ITEM NO.</b>	<b>DESCRIPTION</b>	<b>STOCK NO.</b>	<b>MFG. NO.</b>	<b>MANUFACTURER</b>
1	CONDENSING UNIT	311937	AE2413ZC(1/2)	TECUMSEH
2	PRESSURE CONTROL	280610	012-4834-000	RANCO
3	FILTER / DRIER	282300	C-052-T-HHS	SPORLAN
4	SIGHT GLASS	282400	SA-12S	SPORLAN
5	EXPANSION VALVE (FREZ.)	282575	Q-0(1/6T)-RZ-5'	SPORLAN
6	UNIT COOLER (FREEZER)	312110	KL-015A	SPORLAN
5A	EXPANSION VALVE POWER HEAD(REF) * USED WITH Q-0(1/6T) EXPANSION VALVE BODY	282570	KT-43-PC(power head)	SPORLAN
6A	UNIT COOLER (REF.)	312300	BBM-11A	BOHN
7	TOGGLE SWITCH	335910	TA205-PWB	CARLING
8	THERMOMETER	500000	10-6812-01-4	COOPER
9	ANTI-CONDENSATE PAN	237900	T12-5000	COMPONENT HDWR
10	CASTERS	30810	2-4056-43	JARVIS AND JARVIS
11	AXIAL FAN	312400	028021	CON-AIR ROTRON
12	ACCUMULATOR	281700	3616	REFRIG. RESEARCH
13	DEFROST TIMER	356700	8045-00/120V	PARAGON
14	CRANKCASE PRESS. REG.	281800	CRO-4	SPROLAN
15	LIQUID LINE SOLENOID	281600	A3F1/120	SPORLAN
16	TERMOSTAT (FREEZER)	281010	A30-3857-000	RANCO
17	TERMOSTAT (REF.)	280810	K12-I 1548	RANCO



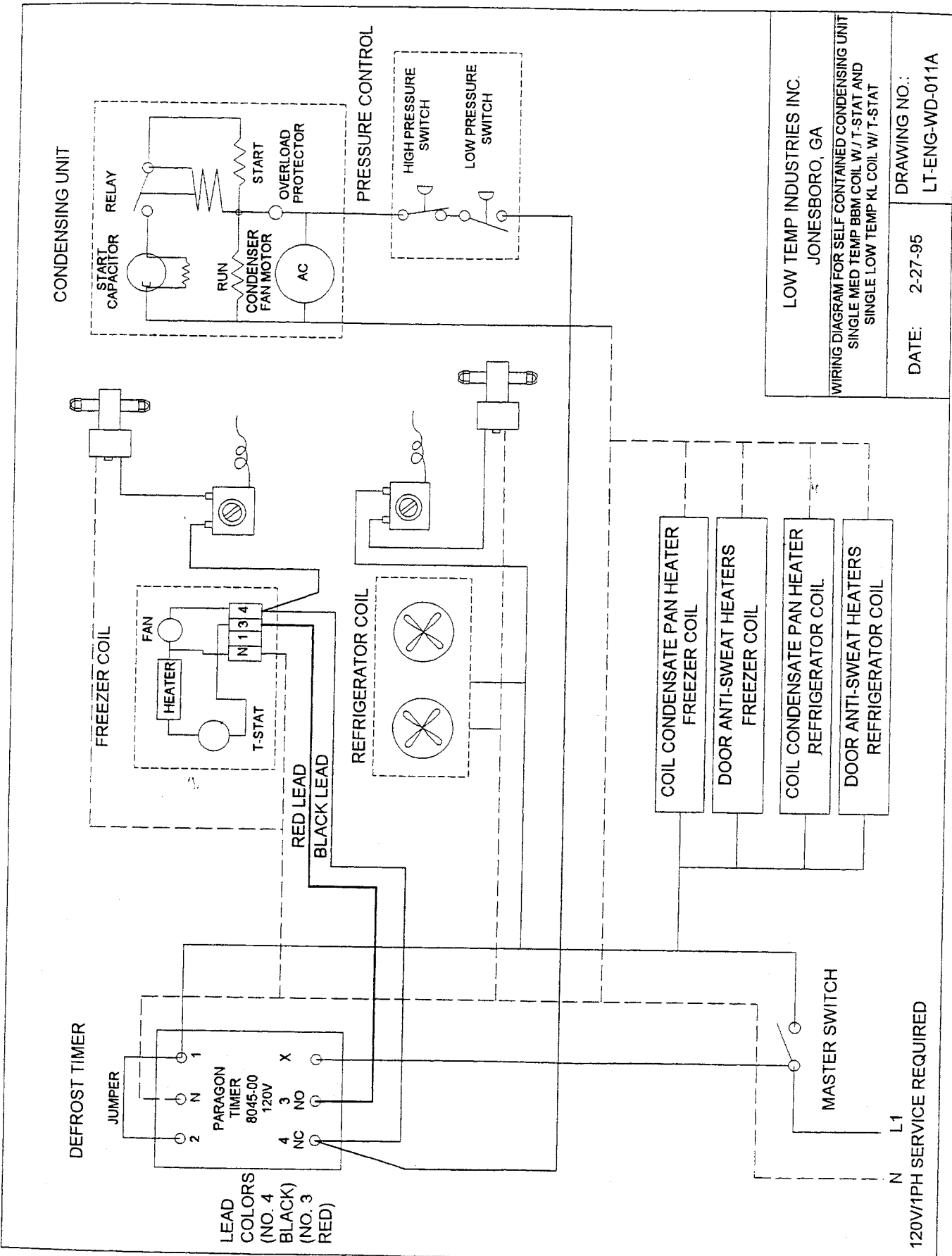

CONDENSING UNIT

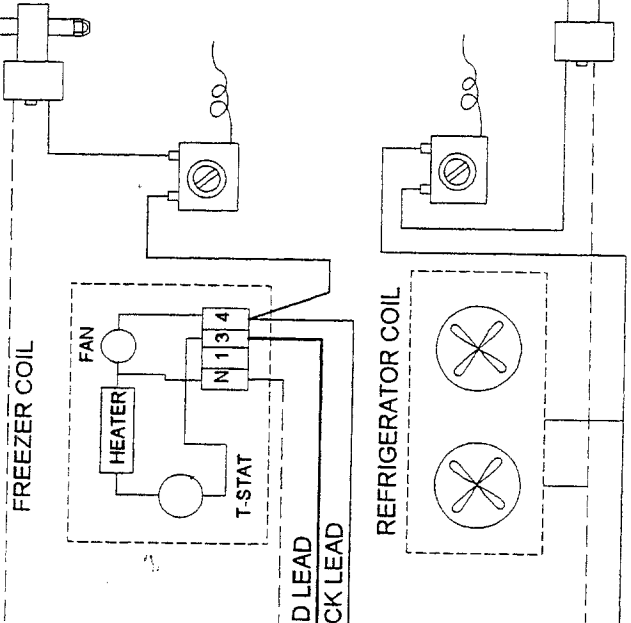
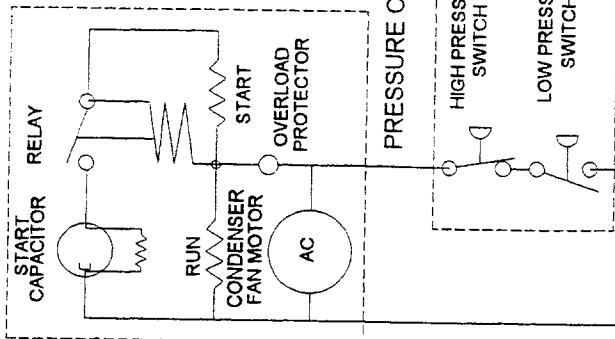

DEFROST TIMER

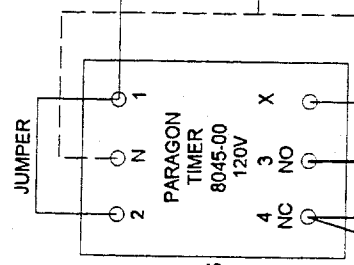

LEAD COLORS  
(NO. 4 BLACK)  
(NO. 3 RED)

LOW TEMP INDUSTRIES INC.  
JONESBORO, GA

WIRING DIAGRAM FOR SELF CONTAINED CONDENSING UNIT  
SINGLE MED TEMP BBM COIL W/ T-STAT AND  
SINGLE LOW TEMP KL COIL W/ T-STAT

DATE: 2-27-95  
DRAWING NO.: LT-ENG-WD-011A

- COIL CONDENSATE PAN HEATER
- FREEZER COIL
- DOOR ANTI-SWEAT HEATERS
- FREEZER COIL
- COIL CONDENSATE PAN HEATER
- REFRIGERATOR COIL
- DOOR ANTI-SWEAT HEATERS
- REFRIGERATOR COIL

MASTER SWITCH

N L1

120V/1PH SERVICE REQUIRED

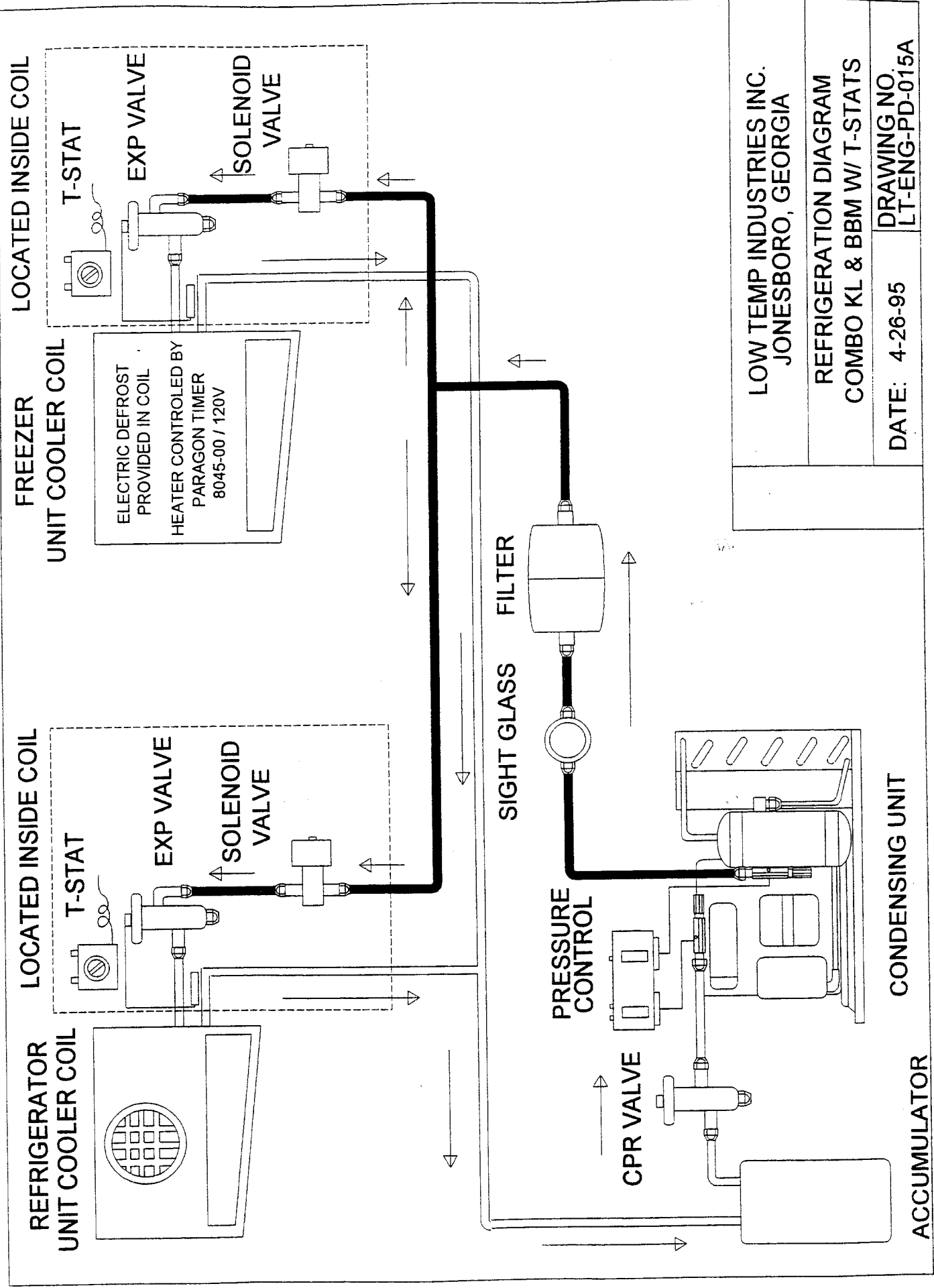

LOW TEMP INDUSTRIES INC.  
 JONESBORO, GEORGIA

REFRIGERATION DIAGRAM  
 COMBO KL & BBM W/ T-STATS

DATE: 4-26-95

DRAWING NO.  
 LT-ENG-PD-015A

## **BASIC SYSTEM OPERATION (REFRIGERATION SYSTEM)**

FOLLOWING SECTION IS DESIGNED TO GIVE A BASIC WORKING KNOWLEDGE OF OUR SYSTEM. IT SHOULD NOT BE USED AS A TRAINING MANUAL FOR NON QUALIFIED REFRIGERATION TECHNICIANS.

ALL COLORPOINT REFRIGERATED EQUIPMENT EMPLOY A COMPRESSION CYCLE SYSTEM. THERE ARE TWO PRESSURES WHICH EXIST IN A COMPRESSION SYSTEM; THE EVAPORATING OR LOW PRESSURE, AND THE CONDENSING OR HIGH PRESSURE.

THE REFRIGERANT WORKS AS A TRANSPORTATION MEDIUM TO MOVE HEAT FROM THE EVAPORATOR TO THE CONDENSER WHERE IT IS GIVEN OFF TO THE AMBIENT AIR. THE CHANGE OF STATE FROM LIQUID TO VAPOR AND BACK ALLOWS THE REFRIGERANT TO ABSORB AND DISCHARGE LARGE QUANTITIES OF HEAT EFFICIENTLY.

THE BASIC SYSTEM OPERATES AS FOLLOWS:

HIGH PRESSURE LIQUID REFRIGERANT IS FED FROM THE RECEIVER THROUGH THE LIQUID LINE AND THROUGH THE FILTER DRIER AND SIGHT GLASS TO THE EXPANSION VALVE WHICH WORKS AS A METERING DEVICE SEPARATING THE HIGH PRESSURE SIDE OF THE SYSTEM FROM THE LOW PRESSURE EVAPORATOR.

THE THERMOSTATIC EXPANSION VALVE CONTROLS THE FEED OF LIQUID REFRIGERANT TO THE EVAPORATOR, AND BY MEANS OF AN ORIFICE REDUCES THE PRESSURE OF THE REFRIGERANT TO THE EVAPORATING OR LOW PRESSURE SIDE.

THE REDUCTION OF PRESSURE ON THE LIQUID REFRIGERANT CAUSES IT TO BOIL OR VAPORIZE UNTIL THE REFRIGERANT IS AT THE SATURATED TEMPERATURE CORRESPONDING TO ITS PRESSURE. AS THE LOW TEMPERATURE REFRIGERANT PASSES THROUGH THE EVAPORATOR COIL, HEAT FLOWS THROUGH THE WALLS OF THE EVAPORATOR TUBING TO THE REFRIGERANT, CAUSING THE BOILING ACTION TO CONTINUE UNTIL THE REFRIGERANT IS COMPLETELY VAPORIZED.

THE EXPANSION VALVE REGULATES THE FLOW THROUGH THE EVAPORATOR AS NECESSARY TO MAINTAIN A PRESET TEMPERATURE DIFFERENCE OR SUPER HEAT BETWEEN THE EVAPORATING REFRIGERANT AND VAPOR LEAVING THE EVAPORATOR. AS THE TEMPERATURE OF THE GAS LEAVING THE EVAPORATOR VARIES THE EXPANSION VALVE POWER ELEMENT BULB SENSES ITS TEMPERATURE, AND ACTS TO MODULATE THE FEED THROUGH THE EXPANSION VALVE AS REQUIRED.

THE REFRIGERANT VAPOR LEAVING THE EVAPORATOR TRAVELS THROUGH THE SUCTION LINE TO THE COMPRESSOR INLET. THE COMPRESSOR TAKES THE LOW PRESSURE VAPOR AND COMPRESSES IT, INCREASING BOTH THE PRESSURE AND THE TEMPERATURE. THE HOT, HIGH PRESSURE GAS IS FORCED OUT THE COMPRESSOR DISCHARGE VALVE AND INTO THE CONDENSER.

AS THE HIGH PRESSURE GAS PASSES THROUGH THE CONDENSER, IT IS COOLED BY A FAN BLOWING OVER A FIN-TYPE CONDENSER SURFACE. AS THE TEMPERATURE OF THE REFRIGERANT VAPOR REACHES THE SATURATION TEMPERATURE CORRESPONDING TO THE HIGH PRESSURE IN THE CONDENSER, THE VAPOR CONDENSES INTO A LIQUID AND FLOWS BACK INTO THE RECEIVER TO REPEAT THE CYCLE.

THE REFRIGERATION PROCESS IS CONTINUED AS LONG AS THE COMPRESSOR OPERATES. THE COMPRESSOR OPERATION IS CONTROLLED BY A LOW PRESSURE CONTROL. WHEN THE REFRIGERANT VAPOR ENTERING THE SUCTION SIDE OF THE COMPRESSOR REACHES A PRESET VALUE ON THE CONTROL, IT WILL OPEN A SET OF CONTACTS AND SHUT THE COMPRESSOR OFF.

THE TEMPERATURE INSIDE THE PRODUCT AREAS ARE CONTROLLED BY THERMOSTATS WHICH ARE MOUNTED INSIDE THE UNIT COOLERS. THE SENSING PROBE FROM THE THERMOSTAT IS LOCATED INSIDE THE FINNED SECTIONS OF THE UNIT COOLERS. WHEN THE THERMOSTATS ARE SATISFIED THE THERMOSTAT CLOSES A LIQUID LINE SOLENOID WHICH STOPS THE FLOW OF REFRIGERANT TO THE UNIT COOLER. WHEN THIS HAPPENS THE COMPRESSOR PUMPS DOWN AND CYCLES OFF ON THE LOW PRESSURE CONTROL. THE REFRIGERATED BASES ARE SUPPLIED WITH A CONSTANT CUT-IN THERMOSTAT WHICH WILL NOT COME ON UNTIL THE COIL HAS RISEN TO A TEMPERATURE OF 37 DEGREES F. THIS ALLOWS THE COIL TO DEFROST AND CLEAR ANY MOISTURE WHICH MAY HAVE ACCUMULATED. THE FREEZER COIL DEPENDS UPON AN ELECTRIC DEFROST CYCLE TO CLEAR THE COIL. THE FREEZER COIL IS PROVIDED WITH A 750W/120V HEATING ELEMENT AND A HIGH LIMIT THERMOSTAT. THIS SYSTEM DOES NOT HAVE A FAN DELAY CIRCUIT AND THE FANS WILL RUN ALL THE TIME. THIS IS NECESSARY TO CLEAR THE MOISTURE FROM THE MULLION TYPE COIL USED IN THIS SYSTEM.

## **ONE YEAR WARRANTY**

ALL COLORPOINT FOOD SERVICE EQUIPMENT IS FULLY WARRANTED BY THE MANUFACTURER AGAINST DEFECTS IN MATERIALS OR WORKMANSHIP FOR A PERIOD OF ONE (1) YEAR FROM THE DATE OF PURCHASE BY THE ORIGINAL USER AND ONLY TO THE ORIGINAL PURCHASER PROVIDED IT IS INSTALLED AND OPERATED IN ACCORDANCE WITH THE INSTRUCTIONS SUPPLIED WITH THE UNIT. ALSO, IT MUST NOT BE MISUSED, ALTERED OR NEGLECTED AND USED ONLY ON CIRCUITS AND VOLTAGES REQUIRED FOR THAT UNIT.

OUR OBLIGATION UNDER THIS WARRANTY SHALL BE LIMITED TO ONE OF THE FOLLOWING PROCEDURES. SELECTION OF A PROCEDURE SHALL BE AT THE SOLE DISCRETION OF LOW TEMP INDUSTRIES-INC.

- A. REPLACEMENT OF DEFECTIVE PARTS, SHIPPED F.O.B. FACTORY, IN EXCHANGE FOR THE RETURNED DEFECTIVE PART, SHIPPED PREPAID FREIGHT.
- B. FREE REPLACEMENT OF DEFECTIVE PART, SHIPPED F.O.B. FACTORY.
- C. DEFECTIVE PART SHIPPED PREPAID FREIGHT TO FACTORY, REPAIRED AND RETURNED, SHIPPED F.O.B.. FACTORY.
- D. ALL LABOR COSTS SHALL BE COVERED FOR A PERIOD OF 1 YEAR FROM THE DATE OF PURCHASE.

LOW TEMP INDUSTRIES INC. SHALL NOT BE RESPONSIBLE FOR ANY DAMAGE CAUSED BY FIRE, FLOOD, WINDSTORM, OR ANY OTHER ACT OF GOD; WAR, WHETHER DECLARED OR UNDECLARED NOR SHALL WE BE RESPONSIBLE FOR THE LOSS OF FOOD OR OTHER PRODUCTS DUE TO POWER OR MECHANICAL FAILURE. THIS WARRANTY SHALL NOT COVER ANY DAMAGE CAUSED DURING SHIPMENT WHICH SHOULD BE REPORTED TO THE DELIVERING CARRIER.

**COLORPOINT FIBERGLASS FOOD SERVICE EQUIPMENT**

**A DIVISION OF LOW TEMP INDUSTRIES INC.**

**9192 TARA BOULEVARD**

**JONESBORO, GEORGIA 30236**

**(770) 478-8803**

# **FIVE YEAR COMPRESSOR WARRANTY**

ALL COLORPOINT MECHANICALLY REFRIGERATED EQUIPMENT CARRIES AN EXTENDED COMPRESSOR WARRANTY BY LOW TEMP INDUSTRIES, INC.

THIS EXTENDED WARRANTY BEGINS ON THE EXPIRATION DATE OF THE ONE (1) YEAR WARRANTY BY THE COMPRESSOR MANUFACTURER AND WARRANTS THE COMPRESSOR AGAINST DEFECTS IN MATERIALS OR WORKMANSHIP FOR A PERIOD OF FOUR (4) YEARS TO THE ORIGINAL USER AND ONLY TO THE ORIGINAL PURCHASER PROVIDED IT IS INSTALLED AND OPERATED IN ACCORDANCE WITH THE INSTRUCTIONS SUPPLIED WITH THE UNIT.

THIS WARRANTY COVERS ONLY THE COMPRESSOR AND DOES NOT INCLUDE ANY RETURN SHIPPING CHARGES, OTHER TRANSPORTATION CHARGES, ANY EXTERNAL PARTS OR ELECTRICAL COMPONENTS, LABOR, REFRIGERANTS OR TAXES.

WARRANTY SHALL BE VOID IF THE UNIT HAS BEEN MISUSED, ALTERED OR NEGLECTED. THE SERIAL NUMBER SHALL NOT BE REMOVED OR DEFACED, AND THE UNIT SHALL BE USED ONLY ON CIRCUITS AND VOLTAGES REQUIRED FOR THAT UNIT.

OUR OBLIGATION UNDER THIS EXTENDED WARRANTY SHALL BE LIMITED TO ONE OF THE FOLLOWING PROCEDURES:

A. REPLACEMENT OF DEFECTIVE COMPRESSOR, SHIPPED FREIGHT PREPAID, IN EXCHANGE FOR THE RETURNED DEFECTIVE COMPRESSOR, SHIPPED PREPAID FREIGHT.

B. REPLACEMENT OF DEFECTIVE COMPRESSOR AT A LOCAL REFRIGERATION SUPPLY HOUSE, IN EXCHANGE FOR THE DEFECTIVE COMPRESSOR.

NO REPLACEMENT OF COMPRESSOR(S) WILL BE AUTHORIZED UNDER EXTENDED WARRANTY WITHOUT ACCURATE VERIFICATION OF SERIAL NUMBER(S) OF DEFECTIVE COMPRESSOR(S).

LOW TEMP INDUSTRIES, INC. MUST BE NOTIFIED PRIOR TO COMPRESSOR REPLACEMENT FOR A WARRANTY AUTHORIZATION NUMBER. ANY REQUESTS FOR WARRANTY CLAIMS WITHOUT A WARRANTY AUTHORIZATION NUMBER, WILL NOT BE HONORED.

THIS EXTENDED WARRANTY DOES NOT COVER ANY DAMAGES CAUSED BY FIRE, FLOOD, WINDSTORM, OR ANY OTHER ACT OF GOD; WAR, WHETHER DECLARED OR UNDECLARED NOR SHALL BE RESPONSIBLE FOR THE LOSS OF FOOD OR OTHER PRODUCTS DUE TO POWER OR MECHANICAL FAILURE.

## **COLORPOINT FIBERGLASS FOOD SERVICE EQUIPMENT**

**A DIVISION OF LOW TEMP INDUSTRIES INC.**

**9192 TARA BOULEVARD**

**JONESBORO, GEORGIA 30236**

**(770) 478-8803**