



Heated Pass-thru Merchandiser

Job: _____

Item: _____

Quantity: _____



Counter Top Models

- | | |
|---|-------------------|
| <input type="checkbox"/> HM-27 | length
27 3/4" |
| <input type="checkbox"/> HM-48 | 48" |
| <input type="checkbox"/> HM-FF with fry station | 46 1/2" |

Benefits:

- ▶ Easy to clean
- ▶ Maximizes presentation
- ▶ Loads from back
- ▶ Durable hard-coated shelves
- ▶ Individual heat controls for energy savings
- ▶ Lighted signage "sells" your product
- ▶ Protected areas for product information

Standard Features

- ✓ Lighted signage and graphics
- ✓ Display area for product labels
- ✓ Adjustable dividers
- ✓ Stainless steel interior
- ✓ Hard-coated shelves
- ✓ Removable interior components
- ✓ Infra-red heat strips
- ✓ Lighted shelves
- ✓ 6' cord and plug
- ✓ 200 powder coat colors
(specify RAL#'s _____)
- ✓ Non-skid, Non-marking feet

Optional Features (specify)

- Custom sign/logo
(specify _____)
- Other voltages (specify _____)
- Additional divider bars
- Stainless steel exterior
- Floor stand

Performance

These heavy-duty, versatile units are designed to maintain proper holding temperatures and provide fast loading and product delivery. Multi-heat sources and controls save energy and adjustable slides accommodate multiple product sizes. All interior racks and dividers are easily removed without tools for fast adjustment and clean-up. Hard-coated shelves provide scratch-resistant durability. Lighted signage allows focus on the presentation of your product to increase impulse sales.





Heated Pass-thru Merchandiser

Job: _____

Item: _____

Quantity: _____

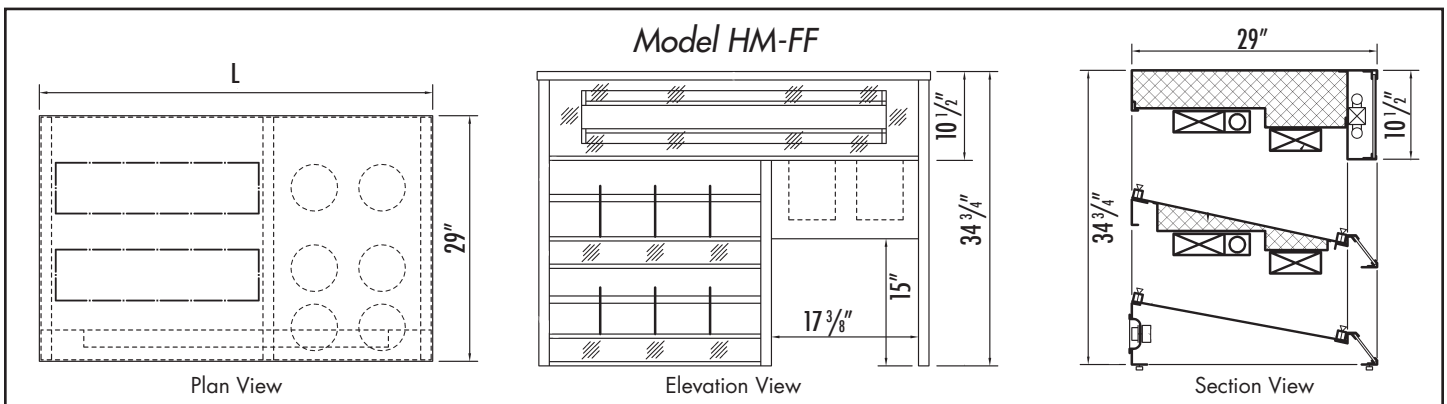
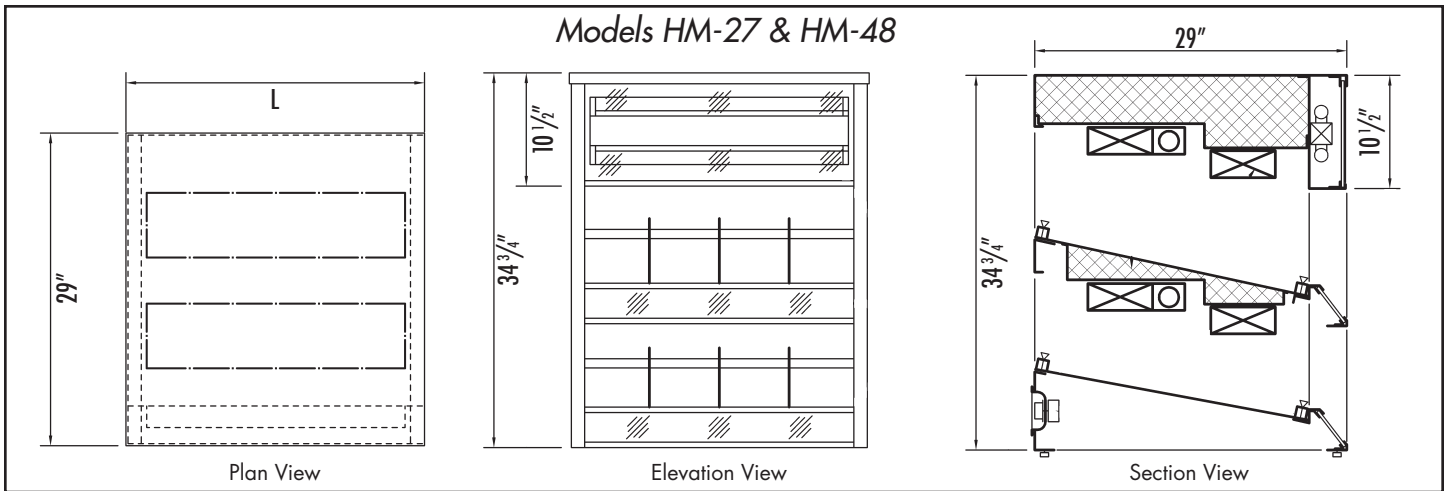

Model	Length	Height	Depth	120V/1		208V/1		Ship Weight	Notes
				Amps	Plug	Amps	Plug		
HM-1	27 3/4"	34 3/4"	29"	14.4	5-20P	9.6	14-20P	200 lbs.	
HM-2	48"	34 3/4"	29"	26	5-20P	17.0	14-30P	300 lbs.	
HM-FF*	46 1/2"	34 3/4"	29"	14.4 12.5	5-20P 5-20P	22.1	14-30P	275 lbs.	Merchandiser Fry Station

*In 120V configuration, this unit has 2 cords and 120V plugs.

Short Form Specifications

Heated merchandiser models to have all welded powder coated exterior and type 304 18-8 stainless steel interior with hard-coated aluminum shelves. Two infra-red heat strips to be located above each shelf with individual infinite controls located on rear of unit and out of heat zone. Each shelf to be lighted, as well as the top front display panel, with separate on/off switches. Merchandiser shall have protected area in front of

each shelf for product graphics (graphics by others). All electric components to be individually fused, and the merchandiser shall be UL listed. Model with fry station (HM-FF) to have 6 each, 250 watt incandescent heat lamps.

We reserve the right to change specifications and product design without notice. Such revisions do not entitle the buyer to corresponding changes, improvements, additions or replacement for previously purchased equipment.

All equipment to be built in accordance with the Underwriters Laboratories, Inc. and the National Sanitation Foundation, Inc. standards and shall bear the Underwriters Laboratories, Inc. listing label for safety and the Underwriters Laboratories classification label for sanitation.

05/2006



P.O. Box 795 • Jonesboro, GA 30237
 Tel: 770.478.8803 • Fax: 770.471.3715
 www.lowtempind.com • colorpoint@lowtempind.com

U.L. Sanitation Classified to NSF Standards

