

Job: _____

Item: _____

Quantity: _____

Rack Dispenser for trays, dishes or silverware



TD-1620

Shown with optional laminate plastic panels, silverware, and napkin dispensers

Models

	rack size
<input type="checkbox"/> TD-1014	10"x14"
<input type="checkbox"/> TD-1020	10"x20"
<input type="checkbox"/> TD-1418	14"x18"
<input type="checkbox"/> TD-1620	16"x20"
<input type="checkbox"/> TD-1622	16"x22"
<input type="checkbox"/> TD-2020	20"x20"

Standard Features

- ✓ Self-leveling dispensers
- ✓ Corner bumpers
- ✓ 4" swivel casters with brakes

Optional Features (specify)

- (OO) Silverware dispenser
- (PP) Napkin dispenser (pair)
- (SS) Stainless steel legs
- (TT) Wrap-around bumpers
- (YY) Laminate plastic body panels
- (ZZ) Stainless steel body panels
- 5" Swivel casters

Benefits:

- ▶ Heavy duty stainless steel construction
- ▶ Large capacity
- ▶ Sizes to fit virtually all racks
- ▶ Mobile, easy to move from dish-room to serving area
- ▶ Easy to clean design



Rack Dispenser for trays, dishes or silverware

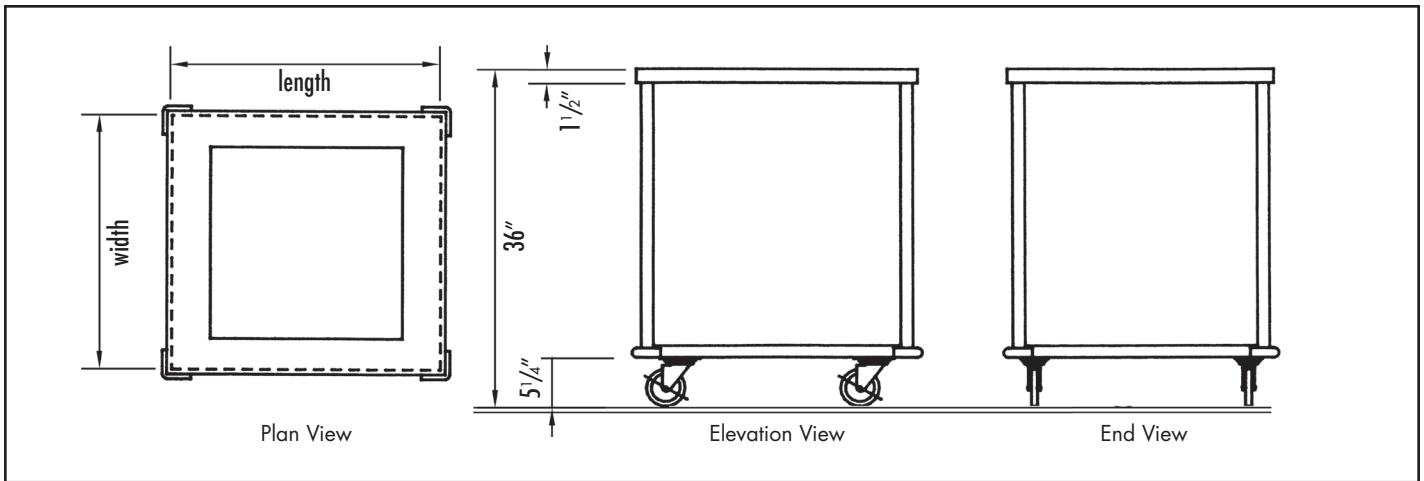

Note: Add 2" for corner bumpers

Model	Length x width x height	Tray Size	Approx. Ship Weight
TD-1014	23" x 18" x 36"	10" x 14"	140 lbs.
TD-1020	29" x 23 1/4" x 36"	10" x 20"	105 lbs.
TD-1418	29" x 23 1/4" x 36"	14" x 18"	115 lbs.
TD-1620	29" x 23 1/4" x 36"	16" x 20"	130 lbs.
TD-1622	31" x 23 1/4" x 36"	16" x 22"	130 lbs.
TD-2020	29" x 27 1/4" x 36"	20" x 20"	145 lbs.

NOTE: When ordering, please specify body panel color and optional extras.

General Specifications

Top: Top fabricated from a minimum of 14 gauge stainless steel with square turndown on all sides and corners fully welded, ground and polished. Top to have #4 satin finish and all edges having #7 hi-lite finish

Body and Frame: Frame to be 14 gauge stainless steel construction. Full perimeter top and bottom frame fully welded, ground and polished to vertical corner uprights making body frame one integral unit. Non-marking corner bumpers secured to bottom frame. Body panels to be fiberglass reinforced polyester (F.R.P.) with smooth exterior surface. All fiberglass to be flame retardant per specification ASTM E-162 having a flame spread of 25 or less.

Dispensers: The top opening shall contain a stainless steel self-leveling dispenser. Dispensing mechanism shall be constructed with automatic self-leveling elevators, enclosed in a stainless steel housing. The elevator mechanisms shall be field adjustable without the use of tools and be connected to a removable heavy gauge stainless steel carrier.

Castors: Castors to be 4" diameter, non-marking ball bearing swivel type with brakes on all wheels.

We reserve the right to change specifications and product design without notice. Such revisions do not entitle the buyer to corresponding changes, improvements, additions or replacement for previously purchased equipment.

All equipment to be built in accordance with the Underwriters Laboratories, Inc. and the National Sanitation Foundation, Inc. standards and shall bear the Underwriters Laboratories, Inc. listing label for safety and the Underwriters Laboratories classification label for sanitation.

03/2007