



Tubular Rack Dispenser

Job: _____

Item: _____

Quantity: _____



CPM-MRD-2020

Models

	tray size
<input type="checkbox"/> CPM-MRD-1020	10"x20"
<input type="checkbox"/> CPM-MRD-1418	14"x18"
<input type="checkbox"/> CPM-MRD-1420	14"x20"
<input type="checkbox"/> CPM-MRD-1620	16"x20"
<input type="checkbox"/> CPM-MRD-1818	18"x18"
<input type="checkbox"/> CPM-MRD-1820	18"x20"
<input type="checkbox"/> CPM-MRD-2020	20"x20"
<input type="checkbox"/> CPM-MRD-2-1020	10"x20"

Standard Features

- ✓ Self-leveling dispensers

Optional Features (specify)

- (SS) Stainless steel legs
- (TT) Wrap-around bumpers
- 5" Swivel casters

Benefits:

- ▶ Heavy duty stainless steel construction
- ▶ Large capacity
- ▶ Sizes to fit virtually all racks or trays
- ▶ Mobile, easy to move from dish-room to serving area
- ▶ Easy to clean design



Tubular Rack Dispenser

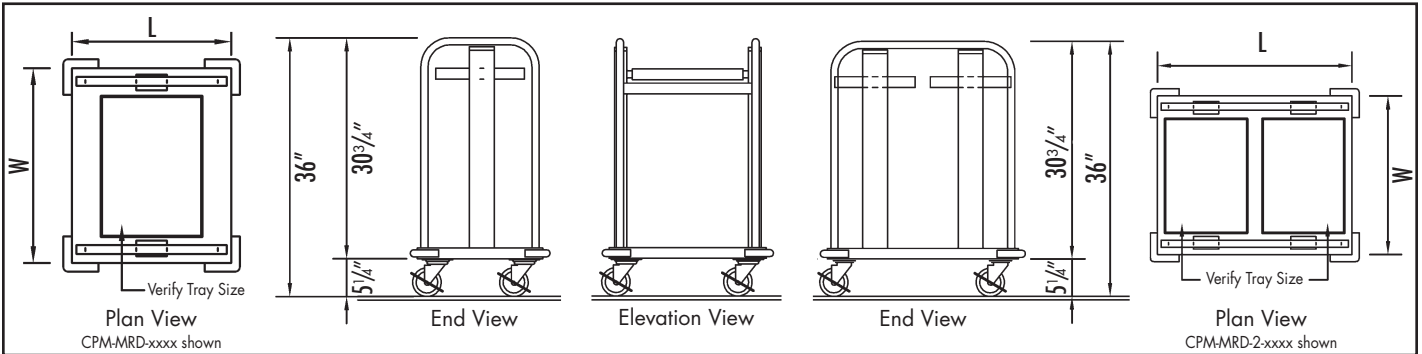

Note: Add 2" for corner bumpers.

Model	L x W x H	Tray Size	Tray Capacity	Tray Stacks	Approx. Ship Weight
CPM-MRD-1020	17 ¹ / ₈ " x 25 ³ / ₄ " x 35 ³ / ₄ "	10"x20"	150	1	65 lbs.
CPM-MRD-1418	21 ¹ / ₈ " x 23 ³ / ₄ " x 35 ³ / ₄ "	14"x18"	150	1	75 lbs.
CPM-MRD-1420	22 ¹ / ₈ " x 25 ³ / ₄ " x 35 ³ / ₄ "	14"x20"	150	1	75 lbs.
CPM-MRD-1620	23 ¹ / ₈ " x 25 ³ / ₄ " x 35 ³ / ₄ "	16"x 20"	150	1	80 lbs.
CPM-MRD-1818	25 ¹ / ₈ " x 23 ³ / ₄ " x 35 ³ / ₄ "	18"x18"	150	1	80 lbs.
CPM-MRD-1820	25 ¹ / ₈ " x 25 ¹ / ₄ " x 35 ³ / ₄ "	18"x 20"	300	2	83 lbs.
CPM-MRD-2020	27 ¹ / ₈ " x 25 ³ / ₄ " x 35 ³ / ₄ "	20"x20"	300	2	83 lbs.
CPM-MRD-2-1020	34 ¹ / ₄ " x 25 ³ / ₄ " x 35 ³ / ₄ "	10"x20"	300	2	90 lbs.

NOTE: When ordering, please verify the following information for proper calibration.

Rack stacking height _____

Rack length _____

Rack width _____

Wt. of loaded rack _____ lbs. _____ oz.

For cups _____ or glasses _____

Diameter of one piece _____

Height of one piece _____

Weight of one piece _____

Max. dia. of one piece _____

Height of one glass _____

Weight of one glass _____

General Specifications

Base and Frame: Base to be fabricated from a minimum of 14 gauge stainless steel with all sides turned square with all corners fully welded, ground and polished. Underside reinforced with heavy gauge channels. Base to have non-marking corner bumpers.

Frame shall be constructed of 1" O.D. 16 gauge stainless steel tubing bolted to the base.

Dispenser Mechanism: Easily removable self-leveling mechanisms shall be field adjustable without the use of tools and shall be supplied with a stainless steel tray platform.

Casters: 4" diameter, ball bearing, swivel type casters to be non-marking and with brakes on all wheels.

We reserve the right to change specifications and product design without notice. Such revisions do not entitle the buyer to corresponding changes, improvements, additions or replacement for previously purchased equipment.

All equipment to be built in accordance with the Underwriters Laboratories, Inc. and the National Sanitation Foundation, Inc. standards and shall bear the Underwriters Laboratories, Inc. listing label for safety and the Underwriters Laboratories classification label for sanitation.

03/2007