



Job: _____

Item: _____

Quantity: _____

Hinged Lid Milk Carton Dispenser



CTAM-7

Models

	length
<input type="checkbox"/> CTAM-5	50 3/8"
<input type="checkbox"/> CTAM-66	66 3/8"
<input type="checkbox"/> CTAM-7	74 3/8"

Benefits:

- ▶ Large capacity of half pint cartons
- ▶ Durable and easy to clean
- ▶ Easy mobility
- ▶ Cartons kept at easy-to-reach height

Standard Features

- ✓ 14 gauge stainless steel tops
- ✓ Insulated stainless steel hinged doors
- ✓ Molded fiberglass body
- ✓ Self-leveling dispensers
- ✓ 6 stainless steel trays per compartment
- ✓ Welded stainless steel interior
- ✓ 4" swivel casters

Optional Features (specify)

- (A) Tray slide, stainless, solid V ridge
- (B) Tray slide, stainless, flat surface
- (D) Cutting board, stainless
- (AA) Cam operated line-up locks
- (DD) Convenience outlet, flush mount
- (EE) Convenience outlet, pedestal mount
- (FF) End drop shelf, stainless
- (GG) Lid Locks
- (SS) Stainless steel legs
- (TT) Wrap-around bumper
- (**) Stainless or laminate body construction (specify)
- 5" swivel casters
- Optional height (specify _____)

Performance

These Heavy Duty, versatile units are designed to maintain proper holding temperatures with a forced air finned coil system. They provide fast, efficient product access through hinged, insulated stainless steel lids that help maintain approved temperatures.





Job: _____

Item: _____

Quantity: _____

Hinged Lid Milk Carton Dispenser

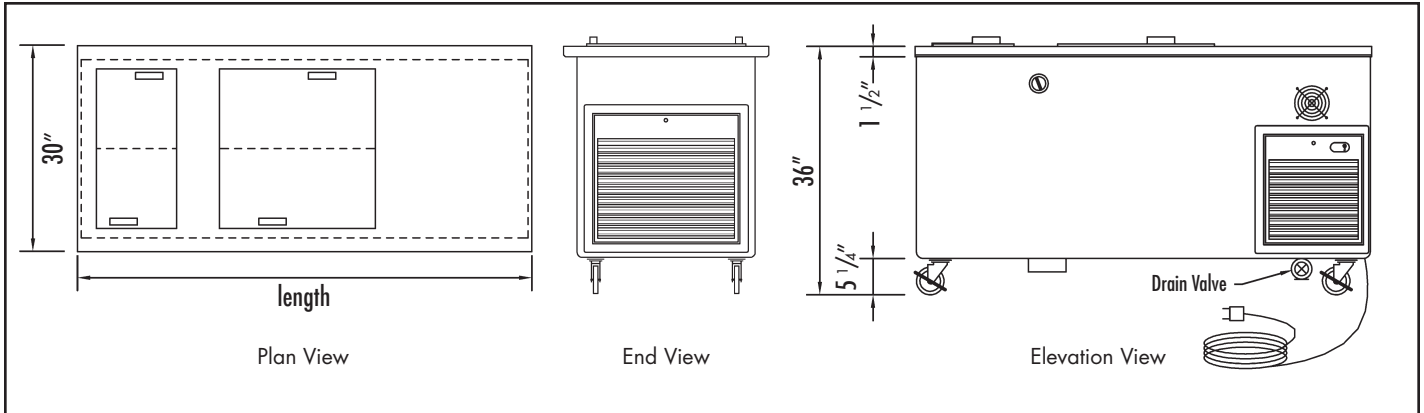

Model	Length	Tray Size	Top Opening	Capacity using 1/2 pt cartons	Comp.	120V/1 phase		Ship Weight
						Amps	Plug	
CTAM-5	50 3/8"	one - 20x20	1	384	1/4 H.P.	10.2	5-15P	325 lbs.
CTAM-66	66 3/8"	one - 10x20 one - 20x20	2	576	1/4 H.P.	10.2	5-15P	460 lbs.
CTAM-7	74 3/8"	two - 20x20	3	768	1/3 H.P.	10.6	5-15P	515 lbs.

General Specifications

Body: Body to be seamless molded fiberglass (F.R.P.) with smooth exterior surfaces and rounded corners. To be constructed by a hand lay-up process with four layers of 1.5 oz continuous strand fiberglass mat, plus a 24 oz layer of woven roving on the bottom for added strength. Fiberglass to be flame retardant per specification ASTM E-162 having a flame spread of 25 or less. Body interior to be reinforced at each end with 4" wide, 12 gauge galvanized channels welded to form integral "U" frame for maximum stress relief.

Top: Top to be 30" wide and fabricated from 14 ga. stainless steel with square turndown on all sides and corners fully welded, ground and polished. Top to have #4 satin finish and all edges having #7 hi-lite finish.

Refrigerated Dispenser: Unit shall have a welded stainless steel watertight interior liner with 2" of urethane foam insulation and full perimeter breaker strips at the top. 1" brass drain shall extend to a shut off valve below the fiberglass body. An interior box temperature of 38 degrees shall be maintained by a finned tube forced air coil with accessible thermostatic expansion valve, and shall include an installed condensate evaporator. Openings will be fitted high impact plastic throat liner and hinged insulated stainless steel lids.

Each opening shall contain a stainless steel self-leveling dis-

penser. Dispensing mechanism shall be constructed with automatic self-leveling elevators, enclosed in a stainless steel housing. The lowerator mechanisms shall be field adjustable without the use of tools and be connected to a removable heavy gauge stainless steel carrier. Each compartment to be furnished with six (6) removable divider trays.

Compressor Housing: Cross flow ventilated compartment to have two stainless steel exterior frames complete with removable stainless steel louvers.

Condensing Unit: Unit to contain a fully hermetic system using R-22 refrigerant, with all necessary controls for proper operation. System to be hooked-up, tested in the factory and made ready to plug in on the job.

Casters: 4" diameter, ball bearing, swivel type casters to be non-marking and with brakes on all wheels. Casters are mounted with exterior and interior bracing for maximum stress relief.

We reserve the right to change specifications and product design without notice. Such revisions do not entitle the buyer to corresponding changes, improvements, additions or replacement for previously purchased equipment.

All equipment to be built in accordance with the Underwriters Laboratories, Inc. and the National Sanitation Foundation, Inc. standards and shall bear the Underwriters Laboratories, Inc. listing label for safety and the Underwriters Laboratories classification label for sanitation.

03/2007



P.O. Box 795 • Jonesboro, GA 30237
 Tel: 770.478.8803 • Fax: 770.471.3715
 www.lowtempind.com • colorpoint@lowtempind.com

U.L. Sanitation Classified to NSF Standards

