



Job: _____

Item: _____

Quantity: _____

Combo Milk and Ice Cream Dispenser



CTAD-74

Models

<input type="checkbox"/> CTAD-66	length 66 3/8"
<input type="checkbox"/> CTAD-74	74 3/8"

Benefits:

- ▶ Ice cream and milk in one convenient unit
- ▶ Large capacity of half pint cartons
- ▶ Durable and easy to clean
- ▶ Easy mobility
- ▶ Cartons kept at easy-to-reach height

Standard Features

- ✓ 14 gauge stainless steel tops
- ✓ Insulated stainless steel hinged doors
- ✓ Molded fiberglass body
- ✓ Self-leveling dispensers
- ✓ 6 stainless steel trays per compartment
- ✓ Welded stainless steel interior
- ✓ 4" swivel casters

Optional Features (specify)

- (A) Tray slide, stainless, solid V ridge
- (B) Tray slide, stainless, flat surface
- (D) Cutting board, stainless
- (AA) Cam operated line-up locks
- (DD) Convenience outlet, flush mount
- (EE) Convenience outlet, pedestal mount
- (FF) End drop shelf, stainless
- (GG) Lid Locks
- (SS) Stainless steel legs
- (TT) Wrap-around bumper
- (**) Stainless or laminate body construction (specify)
- 5" swivel casters
- Optional height (specify _____)

Performance

These Heavy Duty, versatile units are designed to maintain proper holding temperatures with a forced air finned coil system. They provide fast, efficient product access through hinged, insulated stainless steel lids that help maintain approved temperatures. Designed to hold -10F (freezer), and 38F (refrigerator).



Combo Milk and Ice Cream Dispenser

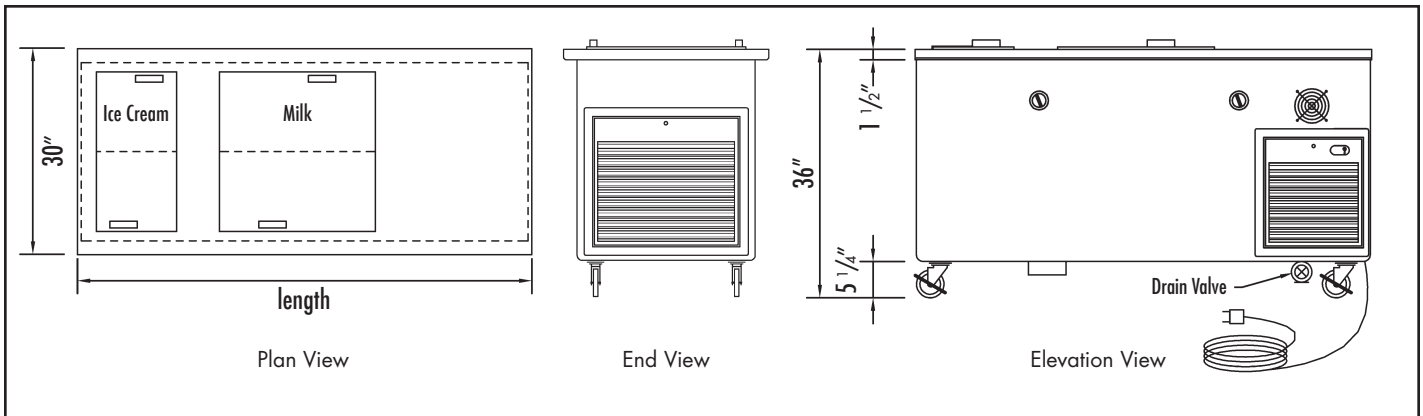

Model	Length	Tray Size	Top Openings	Milk Capacity using 1/2 pt cartons	Ice Cream Capacity using 3 oz cups	Comp.	120V/1 phase		Ship Weight
							Amps	Plug	
CTAD-66	66 3/8"	one - 10x20 - freezer one - 20x20 - refrigerator	2	364	320	1/2 H.P.	16.0	5-20P	550 lbs.
CTAD-74	74 3/8"	one - 20x20 - freezer one - 20x20 - refrigerator	2	364	672	1/2 H.P.	16.0	5-20P	600 lbs.

General Specifications

Body: Body to be seamless molded fiberglass (F.R.P.) with smooth exterior surfaces and rounded corners. To be constructed by a hand lay-up process with four layers of 1.5 oz continuous strand fiberglass mat, plus a 24 oz layer of woven roving on the bottom for added strength. Fiberglass to be flame retardant per specification ASTM E-162 having a flame spread of 25 or less. Body interior to be reinforced at each end with 4" wide, 12 gauge galvanized channels welded to form integral "U" frame for maximum stress relief.

Top: Top to be 30" wide and fabricated from 14 ga. stainless steel with square turndown on all sides and corners fully welded, ground and polished. Top to have #4 satin finish and all edges having #7 hi-lite finish.

Refrigerated Dispenser: Unit shall have a welded stainless steel watertight interior liner with 2" of urethane foam insulation and full perimeter breaker strips at the top. 1" brass drain shall extend to a shut off valve below the fiberglass body. Refrigerated temperature to be maintained at 38 F, (refrigerated section) and -10 F (freezer section) by a forced-air blower coil and an expansion valve system. Freezer section to include an installed condensate evaporator. Openings will be fitted high impact plastic throat liner and hinged insulated stainless steel lids.

Each opening shall contain a stainless steel self-leveling dispenser.

Dispensing mechanism shall be constructed with automatic self-leveling elevators, enclosed in a stainless steel housing. The lowerator mechanisms shall be field adjustable without the use of tools and be connected to a removable heavy gauge stainless steel carrier. Each compartment to be furnished with six (6) removable divider trays.

Compressor Housing: Cross flow ventilated compartment to have two stainless steel exterior frames complete with removable stainless steel louvers.

Condensing Unit: Unit to contain a fully hermetic system using R-507 refrigerant, with all necessary controls for proper operation. System to be hooked-up, tested in the factory and made ready to plug in on the job.

Casters: 4" diameter, ball bearing, swivel type casters to be non-marking and with brakes on all wheels. Casters are mounted with exterior and interior bracing for maximum stress relief.

We reserve the right to change specifications and product design without notice. Such revisions do not entitle the buyer to corresponding changes, improvements, additions or replacement for previously purchased equipment.

All equipment to be built in accordance with the Underwriters Laboratories, Inc. and the National Sanitation Foundation, Inc. standards and shall bear the Underwriters Laboratories, Inc. listing label for safety and the Underwriters Laboratories classification label for sanitation.

03/2007