



# Cashier Station

Item: \_\_\_\_\_

Quantity: \_\_\_\_\_

Project: \_\_\_\_\_

Date: \_\_\_\_\_



28-CSE shown with solid tray slides, cash drawer and fold-down end shelf.

## MODELS

- 28-CSE - end station
- 36-CSE - end station
- 50-CSE - end station
- 60-CSE - end station
- 66-CSE - end station
- 74-CSE - end station
  
- 28-CSS - side station
- 36-CSS - side station
- 50-CSS - side station
- 60-CSS - side station
- 66-CSS - side station
- 74-CSS - side station

### Top:

- 36" counter height
- Top extensions (width \_\_\_\_\_ )
- Top extensions (length \_\_\_\_\_ )
- Drop-in DI-2222-IC frozen merchandiser
- keypad bracket

### Above the top: (50" and longer units)

- Buffet shield, single service
- Buffet shield, double service
- Lift-up hinge
- 2 tier display shelf, single service
- 2 tier display shelf, double service
- 3 tier display shelf, single service
- 3 tier display shelf, double service
- Curved glass
- Powder coat (specify RAL#)
- Flourescent lights

### Electrical Options:

- Convenience outlet, flush
- Convenience outlet, pedestal
- Daisy chain
- Load center

### Tray Slide:

- Stainless Steel
- Solid "V" ridge
- Flat Surface
- Solid Surface
- Corian® (specify \_\_\_\_\_ )
- Powder Coated brackets (specify RAL #)
- 34" Tray Slide Height
- Other Slide Height \_\_\_\_\_

### Base Options:

- Cam operated line-up locks
- Bottom shelf
- Slide-out shelf
- Locking cabinet
- Security cover
- Custom color (specify RAL#)
- 5" diameter casters
- Stainless steel legs
- Other \_\_\_\_\_

### Cash Drawer Options:

- Locking cash box
- Plastic cash tray
- Other (specify \_\_\_\_\_ )

- ▶ Versatile counters, add the options you need!
- ▶ Durable, colorful, molded fiberglass
- ▶ East to clean, low maintenance
- ▶ 50" and longer units can contain a drop-in freezer/merchandiser or display shelves for added versatility.

### Other Options:

- Canopy (specify style & color)
- Over-structure with signage & lights (specify)
- Theme Package
  - School Bus
  - Train
  - Space Shuttle
  - Covered Wagon
  - Circus Train
  - Other (specify)





# Cashier Station

Item: \_\_\_\_\_

Quantity: \_\_\_\_\_

Project: \_\_\_\_\_

Date: \_\_\_\_\_

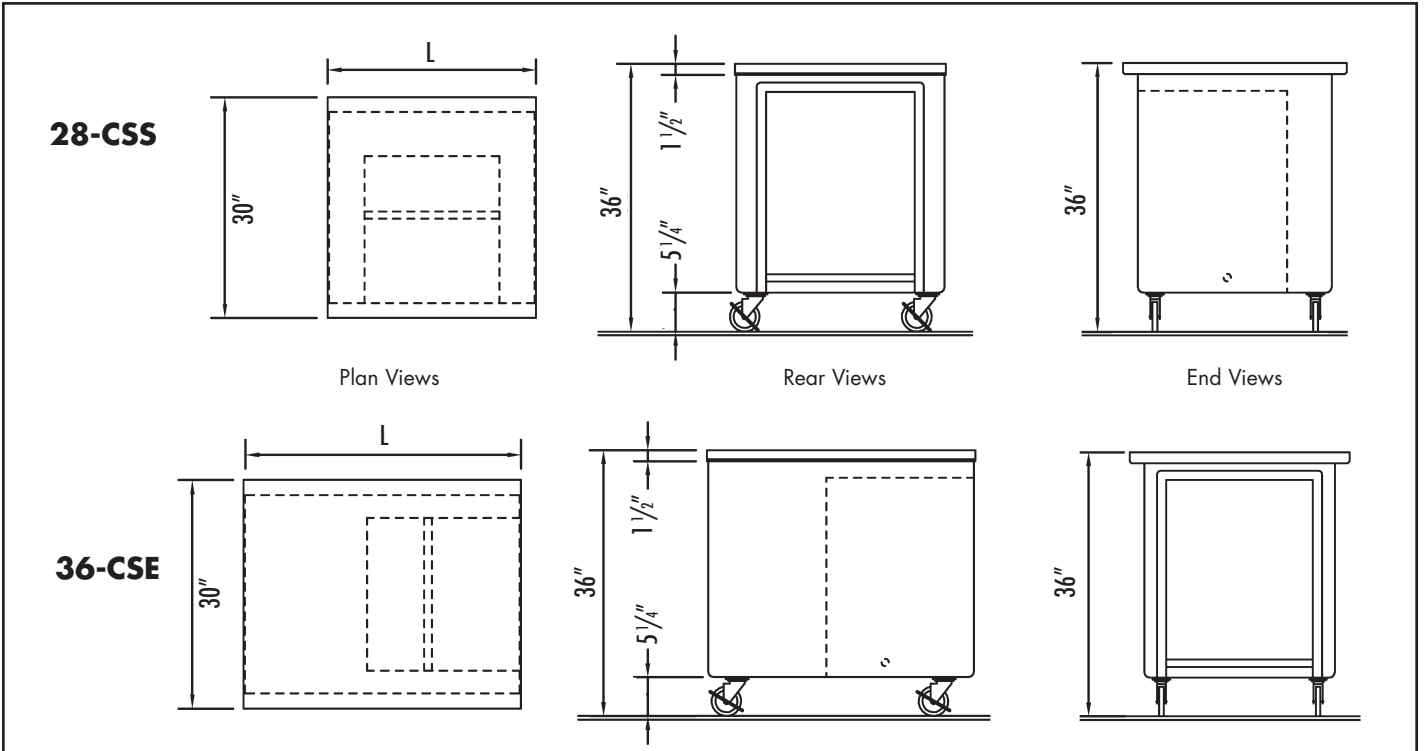

CSE MODELS	L	S*	APPROX. SHIP WEIGHT
28-CSE	28 3/8"	N/A	205 lbs.
36-CSE	36 3/8"	N/A	260 lbs.
50-CSE	50 3/8"	15"	320 lbs.
60-CSE	60 3/8"	28"	205 lbs.
66-CSE	66 3/8"	36"	260 lbs.
74-CSE	74 3/8"	46"	320 lbs.

CSS MODELS	L	S (optional)	APPROX. SHIP WEIGHT
28-CSS	28 3/8"	N/A	205 lbs.
36-CSS	36 3/8"	N/A	260 lbs.
50-CSS	50 3/8"	15"	320 lbs.
60-CSS	60 3/8"	28"	205 lbs.
66-CSS	66 3/8"	36"	260 lbs.
74-CSS	74 3/8"	46"	320 lbs.

\* Represents optional storage compartment mounted in 50" or longer units.

**TOP:** Top to be 30" wide and fabricated from a minimum of 14 ga. stainless steel with square turn-down on all sides and corners fully welded, ground and polished. Top to have #4 satin finish and with all edges having a #7 hi-lite finish.

**BODY:** Body to be seamless molded fiberglass (F.R.P.) with smooth exterior surfaces and rounded corners. To be constructed by a hand lay-up process with four layers of 1.5 oz continuous strand fiberglass mat,

plus a 24 oz layer of woven roving on the bottom for added strength. Fiberglass to be flame retardant per specification ASTM E-162 having a flame spread of 25 or less. Body interior to be reinforced at each end with 4" wide, 12 gauge galvanized channels welded to form integral "U" frame for maximum stress relief.

**CASTERS:** 4" diameter, ball bearing, swivel type casters to be non-marking and with brakes on all wheels. Casters to be mounted

thru two 12 gauge channels for extra rigidity.

We reserve the right to change specifications and product design without notice. Such revisions do not entitle the buyer to corresponding changes, improvements, additions or replacement for previously purchased equipment.

All equipment to be built in accordance with the Underwriters Laboratories, Inc. and the National Sanitation Foundation, Inc. standards and shall bear the Underwriters Laboratories, Inc. listing label for safety and the Underwriters Laboratories classification label for sanitation.

05/2006



P.O. Box 795 • Jonesboro, GA 30237  
 Tel: 770.478.8803 • Fax: 770.471.3715  
 www.lowtempind.com • colorpoint@lowtempind.com

