

OPERATION AND MAINTENANCE MANUAL REPLACEMENT PARTS LIST FOR

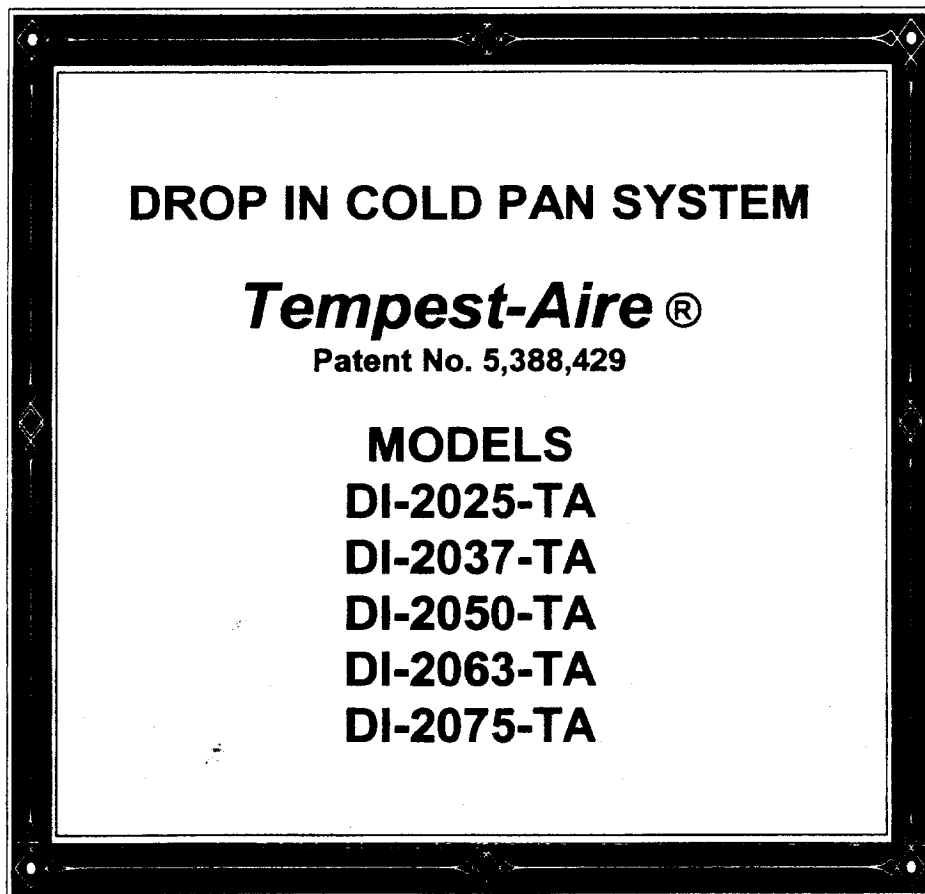

LOW TEMP
MANUFACTURING COMPANY

DIVISION OF LOW TEMP INDUSTRIES, INC
9192 TARA BOULEVARD P.O. BOX 795 JONESBORO, GEORGIA 30237
TELEPHONE: (770) 478-8803

CUSTOM FABRICATORS OF STAINLESS STEEL FOOD SERVICE EQUIPMENT

******* INSPECTION *******

UPON RECEIPT, THE CRATE SHOULD BE INSPECTED FOR VISUAL DAMAGE. ANY DAMAGE SHOULD BE REPORTED IMMEDIATELY TO THE CARRIER.

******* INSTALLATION INSTRUCTIONS *******

THE LOW TEMP DROP IN COLD PAN IS A REFRIGERATION SYSTEM DESIGNED FOR SHORT TERM DISPLAY AND DISPENSING OF FOOD AND DESERTS. THIS UNIT IS DESIGNED TO MAINTAIN A PRODUCT TEMPERATURE AT A MAXIMUM OF 40 DEGREES FAHRENHEIT FOR PERIODS UP TO FOUR (4) HOURS. THESE UNITS ARE DEPENDENT UPON THE AMBIENT TEMPREATURE IN WHICH THEY ARE INSTALLED AND THE PRODUCT TEMPERATURE WHEN IT IS PLACED IN THE UNITS. THE PRODUCT SHOULD BE CAREFULLY MONITORED AND ROTATED AS NECESSARY TO MEET LOCAL HEALTH REQUIREMENTS.

******* OPERATING INSTRUCTIONS *******

START UP:

THE REFRIGERATION SYSTEM SUPPLIED WITH THESE SYSTEMS ARE OF THE HERMETIC TYPE. REFRIGERANT IS METERED BY EXPANSION VALVES WHICH ARE LOCATED IN THE COMPRESSOR HOUSING. EACH REFRIGERATION SYSTEM IS SELF CONTAINED AND HAS BEEN LEAK TESTED, CHARGED WITH REFRIGERANT AND OPERATED TO ENSURE THE PROPER OPERATION AND SETTING OF THE CONTROLS.

ENERGIZE THE UNIT BY ATTACHING THE PLUG TO AN APPROPRIATE ELECTRICAL SUPPLY (115 VAC, 60 HZ, SINGLE PHASE, 12 AMP) AND TURNING ON THE SERVICE SWITCH LOCATED IN THE COMPRESSOR COMPARTMENT. AFTER APPROXIMATELY TWENTY-FOUR HOURS OF OPERATION THE UNIT WILL BE READY FOR USE.

OPERATION:

THE SYSTEM TEMPERATURE IS CONTROLLED BY A THERMOSTAT WHICH IS LOCATED INSIDE THE COMPRESSOR HOUSING. THE THERMOSTAT CONTROLS A LIQUID LINE SOLENOID WHICH CONTROLS THE FLOW OF REFRIGERANT TO THE COOLING COILS. A LOW PRESSURE CONTROL (PHYSICALLY LOCATED IN THE FRONT OF THE COMPRESSOR COMPARTMENT) IS USED TO CYCLE OFF THE COMPRESSOR. THE LOW PRESSURE CONTROL SHOULD NOT BE ADJUSTED FROM THE FACTORY SETTINGS. ADJUSTMENT OF THIS CONTROL MAY CAUSE PERFORMANCE PROBLEMS WITH THE UNIT. THE TEMPERATURE IS DIRECTLY CONTROLLED BY THE THERMOSTAT.

CLEANING:

THE INNER LINER OF THIS UNIT IS FABRICATED OF 304 STAINLESS STEEL. PLEASE SEE "HOW TO CLEAN STAINLESS STEEL" IN THIS MANUAL. NOTE THAT THIS IS A VERY BROAD SECTION ON CLEANING AND THE TYPE OF EQUIPMENT AND END USE SHOULD BE KEPT IN CONSIDERATION BEFORE SELECTING ANY SPECIAL CLEANERS.

ELECTRICAL SYSTEM:

******* WARNING *******

IN ORDER TO PREVENT ANY ELECTRICAL ACCIDENTS, THIS DISPENSER SHOULD BE INSTALLED AND SERVICED BY QUALIFIED MAINTENANCE PERSONNEL ONLY PER NATIONAL ELECTRICAL CODE STANDARDS.

******* WARNING *******

INDIVIDUAL BREAKERS OR FUSES SHOULD BE PROVIDED FOR EACH COMPRESSOR MOTOR. GROUP FUSING, WHERE TWO OR MORE COMPRESSORS ARE INSTALLED ON ONE FUSE OR BREAKER IS ****NOT RECOMMENDED****. REFER TO THE NATIONAL ELECTRICAL CODE FOR APPROPRIATE LINE FUSE OR BREAKER SIZE.

HOW TO CLEAN STAINLESS STEEL

THE FOLLOWING INFORMATION WAS TAKEN FROM A PAMPHLET BY MR. RICHARD E. PARET, STAINLESS STEEL SPECIALIST, AMERICAN IRON AND STEEL INSTITUTE.

STAINLESS STEEL IS ONE OF THE EASIEST MATERIALS TO CLEAN AND KEEP CLEAN.

THE REASONS FOR STAINLESS STEEL'S EASE OF CLEANING ARE EASY TO SEE; THEY LIE IN THE NATURE OF THE METAL ITSELF.

1. IT'S HARD, TOUGH SURFACE. STAINLESS STEEL WILL WORK HARDER, THAT IS, THE MORE IT IS USED, THE MORE RESISTANT TO WEAR IT BECOMES. STAINLESS STEEL WILL NOT DEVELOP ROUGH SPOTS THAT HARBOR BACTERIA AND SOIL.
2. HIGH CORROSIVE RESISTANCE. STAINLESS STEEL IS PRACTICALLY UNTOUCHED BY THE CORROSIVE ATTACKS OF MOISTURE, DETERGENTS, FOOD ACIDS, BLOOD SALTS AND OTHER CORRODENTS CONNECTED WITH FOOD PREPARATION. THIS MEANS THAT STAINLESS STEEL ALWAYS HAS A BRIGHT SURFACE FREE FROM OXIDES THAT CAN AFFECT THE FLAVOR OF FOODS

THE SECRET OF MAINTAINING STAINLESS STEEL IS FREQUENT, SCHEDULED CLEANING THAT WILL PREVENT BUILD UP OF SURFACE DEPOSITS. SURFACE DEPOSITS, IF ALLOWED TO REMAIN FOR LONG PERIODS OF TIME CAN HARM STAINLESS STEEL. STAINLESS STEEL THRIVES ON EXPOSURE TO AIR; UNDER CERTAIN CONDITIONS, THE LENGTHY DEPRIVATION OF OXYGEN BY HEAVY SOIL DEPOSITS CAN CAUSE LOCALIZED PITTING OR STAINING.

NEGLECTING THE MATERIAL IN THIS MANNER IS **DEFINITE ABUSE**, WHICH EVEN STAINLESS STEEL IS NOT IMMUNE.

TWO BASIC RULES:

1. CLEAN FREQUENTLY, AND ON A FIXED SCHEDULE.
2. SELECT THE SIMPLEST METHOD.

TO REMOVE ORDINARY DIRT AND FOOD RESIDUE FROM STAINLESS STEEL EQUIPMENT THAT OPERATES AT LOW TEMPERATURES, USE ORDINARY SOAP AND WATER AND APPLY WITH A SPONGE, FIBER BRUSH OR CLOTH. TO HASTEN ACTION, ADD EITHER SODA ASH, BAKING SODA, BORAX OR ANY OF SEVERAL NON-ABRASIVE COMMERCIAL CLEANSING AGENTS.

TO REMOVE SPLATTER OR CONDENSED VAPOR, WHICH HAVE "BAKED" ONTO THE EQUIPMENT, THE TREATMENT OUTLINED ABOVE IS OFTEN SUFFICIENT. IN OTHER CASES A GENTLE TO VIGOROUS POLISHING ACTION MAY BE NECESSARY.

FIRST TRY A PASTE MADE WITH WATER AND AMMONIA AS THE LIQUID AND EITHER MAGNESIUM OXIDE, FINELY POWDER PUMICE OR FRENCH CHALK AS THE SOLID. YOU CAN ALSO USE ONE OF SEVERAL COMMERCIAL CLEANERS LISTED IN THE FOLLOWING TABLE.

RUB AS GENTLY AS POSSIBLE IN THE DIRECTION OF THE POLISHING MARKS ON THE STEEL, USING A SOFT CLOTH. FOR MORE RESISTANT DEPOSITS, USE A STAINLESS STEEL SCOURING SPONGE OR STAINLESS STEEL WOOL OF THE FINEST POSSIBLE TEXTURE.

WHAT NOT TO DO:

DO NOT USE COMMON STEEL WOOL, SCOURING PADS, SCRAPERS, WIRE BRUSHES, FILES OR OTHER STEEL TOOLS, SINCE THESE CAN MAR THE STAINLESS STEEL. THESE PARTICLES WILL EVENTUALLY RUST AND STAIN THE SURFACE, AND YOU MAY HAVE TO REFINISH IT.

HOW TO CLEAN STAINLESS STEEL (CONT.)

SLIGHTLY DARKENED AREAS SOMETIMES APPEAR ON STAINLESS STEEL SURFACES WHERE HEAT HAS BEEN APPLIED DURING FABRICATION OR IN SERVICE.

THESE ARE CAUSED BY THICKENING OF THE PROTECTIVE SURFACE OF STAINLESS STEEL, AND ARE NOT HARMFUL. REMOVAL CALLS FOR ENERGETIC SCOURING, AGAIN USING STAINLESS STEEL WOOL OR SCOURING PAD, COMBINED WITH A SCOURING POWDER OR ONE OF THE HEAT-TINT REMOVERS LISTED IN THE TABLE.

THREE RULES WILL PREVENT HEAT TINTING:

- 1) USE ONLY ENOUGH HEAT TO DO THE JOB EFFICIENTLY.
- 2) DO NOT APPLY HEAT TO EMPTY EQUIPMENT.
- 3) AVOID CONCENTRATING HEAT ON A SMALL AREA.

CAUTION IS ADVISED

IN STERILIZING STAINLESS STEEL EQUIPMENT, PAY PARTICULAR ATTENTION TO AGENTS CONTAINING CHLORINE COMPOUNDS SUCH AS POTASSIUM HYPOCHLORITE. THESE COMPOUNDS MAY BREAK DOWN AND RELEASE FREE CHLORINE, OR HYDROLYZE TO FORM HYDROCHLORIC ACID.

STAINLESS STEEL RESISTS ATTACK BY SUCH COMPOUNDS FOR UP TO TWO HOURS. SEVERE LOCALIZED PITTING MAY OCCUR FROM LONGER EXPOSURE. FOR SAFE USE OF THESE AGENTS, KEEP CONTACT TIME SHORT, FLUSH THOROUGHLY WITH WATER, AND OPERATE EQUIPMENT NORMALLY BETWEEN APPLICATIONS. USING THESE PRECAUTIONS, THE STERILIZATION PROCESS CAN BE REPEATED ANY NUMBER OF TIMES.

Cleaners and their effect on stainless steel

Cleaning agent	Method of Application	Effect on Finish
<p>1. Tightly adhering deposits of "baked on" spatter, oil, grease, weather stain, dyes or other light discoloration may be removed with any of the following cleaners.</p>		
Grade FFF Italian pumice whitening or bon ami	scour or rub with damp cloth	satisfactory for all finishes use light Pressure on no.7
Liquid NuSteel	scour with small amount on dry cloth	satisfactory for all finishes if rubbing pressure is light
Paste NuSteel or Temp	scour with small amount on dry cloth	satisfactory for no. 4 finish. Will scratch no.7
House hold cleaners such as Old Dutch, Sunbrite, Wyandotte, Bob-O, Gold Dust and Sapolio	Rub with damp cloth	Will scratch no. 4 finish slightly
Grade F Italian Pumice	Rub with damp cloth	Will scratch no.4 finish slightly
Cooper's stainless steel polish	satisfactory	Rub with damp cloth for no.4 finish
Allen stainless steel polish	Rub with damp cloth considerably	Scratches but leaves mirror reflection
Best effect chemical co. cleaner & Passivator	Rub with damp cloth	May scratch no.4 finish slightly
<p>2. Heat tint or heavy discoloration with the following (see notes below)</p>		
Allen stainless polish	Small amount on damp cloth	Excellent heat tint remover
Birdsall's "Staybright"	Rub with damp cloth	Very good for heat tint removal. Does not scratch no.4 finish but does scratch no.7
Wyandotte or Bob-O	Rub with damp cloth heat	Good for tint removal
Oxalic acid (use warm) or 5-15% nitric acid	Swab or immerse. Always follow with a 5% sodium carbonate or neutralizer rinse	Good discoloration remover
Best effect chemical co. cleaner & Passivator	Rub with damp cloth	May scratch no 4 finish but leaves clean surface

**CLEANERS AND THEIR EFFECT ON
STAINLESS STEEL
(Cont.)**

Cleaning agent	Method of Application	Effect on Finish
3. The following detergents and solvents are excellent removers of grease, oil and fatty acids, where swabbing or rubbing is not practical.		
4 to 6% solution of (sodium Metasilicate) (Trisodium Phosphate) (Sodium Metaphosphate) (Sodium Pyrophosphate)		All excellent removers of grease, oil, and milkstone
5-15% caustic soda (hot or cold)		Will remove grease and milkstone
4. The following organic solvents may be used for removing oils and grease deposits:		
Carbon-tetrachloride, Naphtha, Trichlorethylene Acetone, Kerosene, Gasoline, Ether, Alcohol, Benzene		No affect on finish However, take all precautions against fire.

Notes: ordinary wool or steel brushes should never be used on stainless steel surfaces. Particles of steel may become imbedded in the stainless steel surface, and rusting of these particles will eventually appear as stains. Use stainless steel wool or sponge on stainless steel equipment. Heat tint removers will usually scratch stainless steel surfaces. This, however, is necessary in removing heat tint by hand. Oakite, a fibrous material, may be used in place of metal sponges or cloth pads for applying cleaners and polishes. This material is effective in aiding in removal of milkstone.

For heavy hard water deposits, 15-20% (by volume) nitric acid is very effective. Acid treatment should be followed by a thorough water rinse.

The action of soldering fluxes should be neutralized immediately with a 5% sodium carbonate solution. Soap and water followed by a water rinse will not harm stainless steel.

HOW TO ADJUST COREL THERMOSTAT

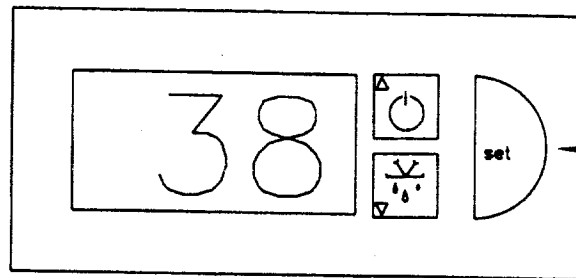

(1)

PRESS AND HOLD SET BUTTON FOR ONE SECOND

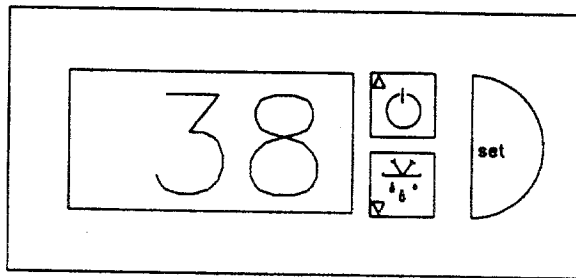

(2)

TEMPERATURE WILL FLASH

(3)

PRESS UP ARROW TO RAISE TEMPERATURE

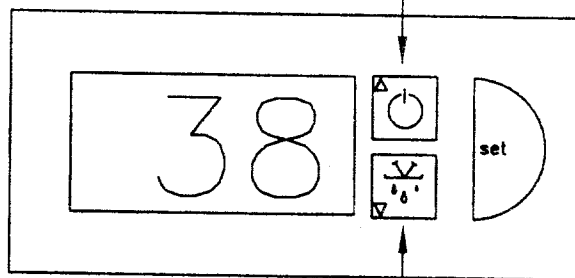

PRESS DOWN ARROW TO LOWER TEMPERATURE

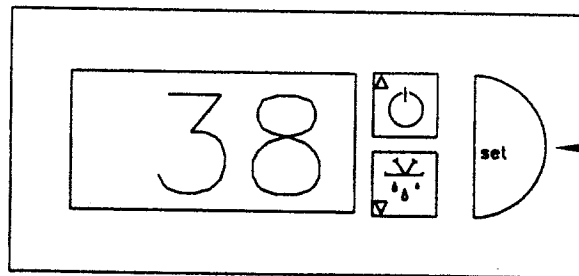

(4)

PRESS AND RELEASE SET BUTTON

IF OTHER ADJUSTMENTS ARE NEEDED PLEASE CONSULT TECHNICAL SUPPORT AT FACTORY 770-478-8803

ORDER #: DRAWN BY: T. TAYLOR REVISIONS: SCALE:		
	<small>LOW TEMP INDUSTRIES, INC. • P.O. BOX 795 • JAMESBORO, GA 30557-0795 • (770) 478-8803</small>	
	PROJECT: COREL-THERMOSTAT	
	DEALER:	
DATE: 07-21-06	SHEET#	DWG# SPORLAN-THERMOSTAT

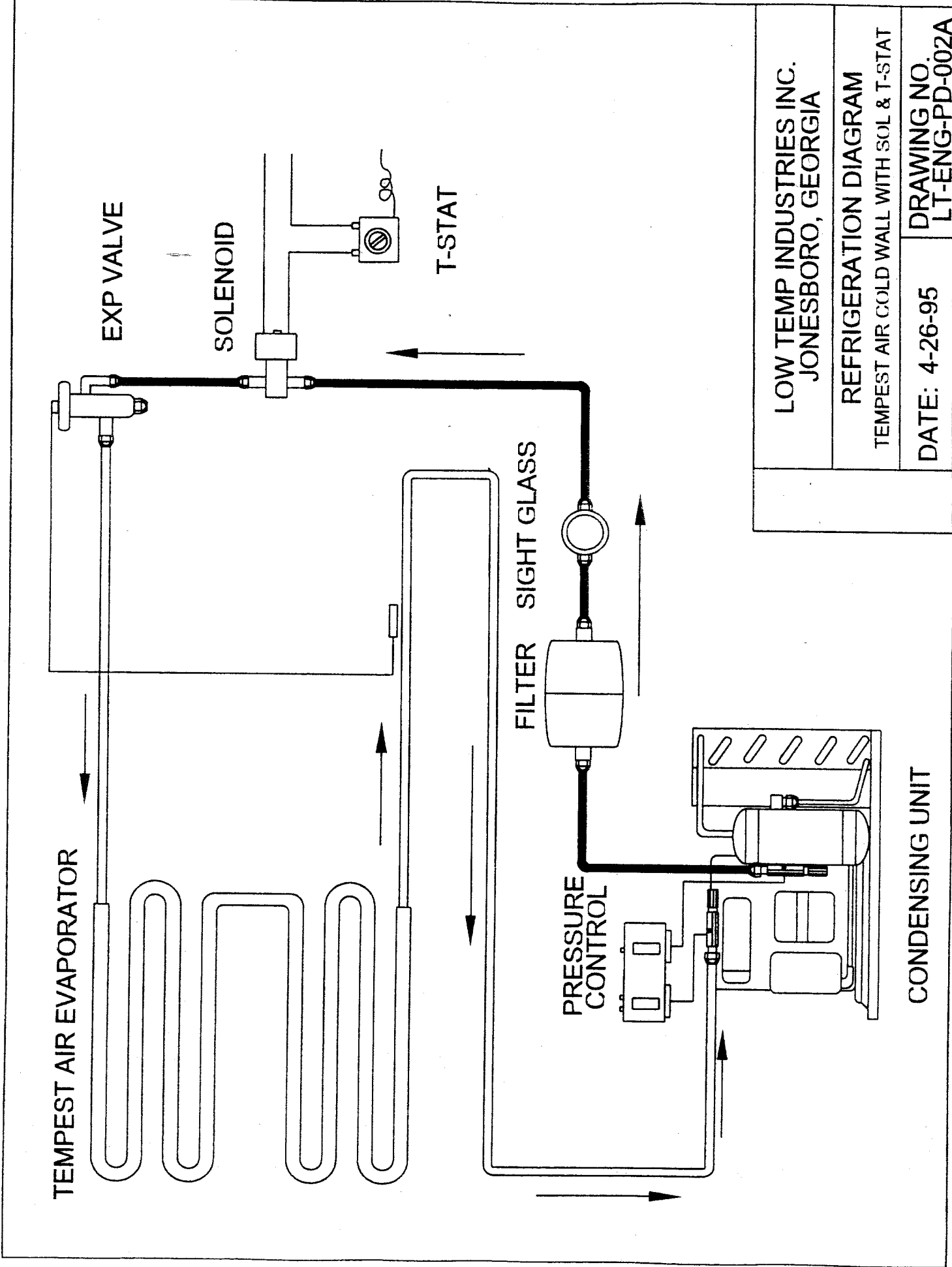

LOW TEMP INDUSTRIES INC.
 JONESBORO, GEORGIA

REFRIGERATION DIAGRAM
 TEMPEST AIR COLD WALL WITH SOL & T-STAT

DATE: 4-26-95

DRAWING NO.
 LT-ENG-PD-002A

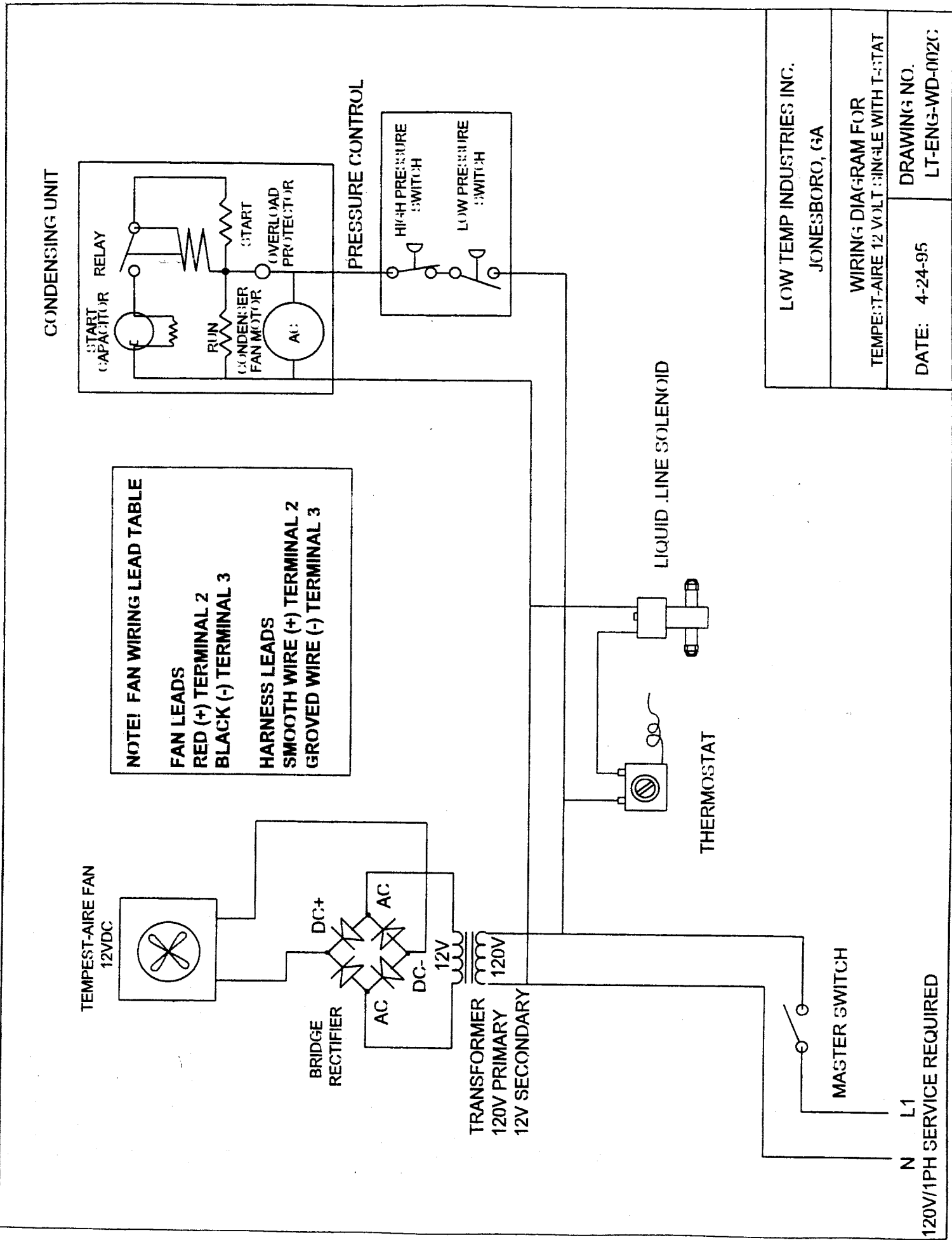

CONDENSING UNIT

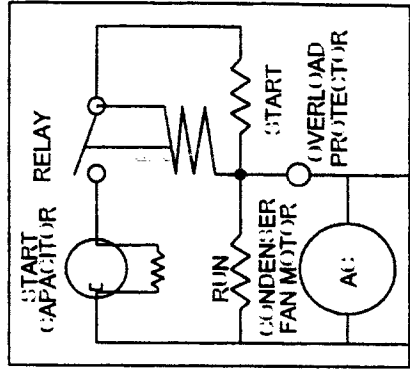

PRESSURE CONTROL

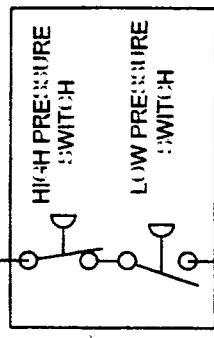

NOTE! FAN WIRING LEAD TABLE
FAN LEADS
 RED (+) TERMINAL 2
 BLACK (-) TERMINAL 3
HARNES LEADS
 SMOOTH WIRE (+) TERMINAL 2
 GROOVED WIRE (-) TERMINAL 3

TEMPEST-AIRE FAN
12VDC

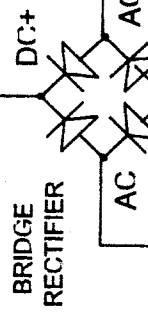
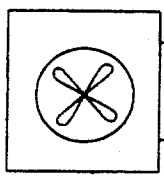

TRANSFORMER
120V PRIMARY
12V SECONDARY

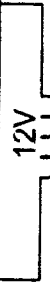

LIQUID LINE SOLENOID



THERMOSTAT



MASTER SWITCH



N L1

120V/1PH SERVICE REQUIRED

LOW TEMP INDUSTRIES INC. JONESBORO, GA	
WIRING DIAGRAM FOR TEMPEST-AIRE 12 VOLT SINGLE WITH T-STAT	
DATE: 4-24-95	DRAWING NO. LT-ENG-WD-002C

CONDENSING UNIT

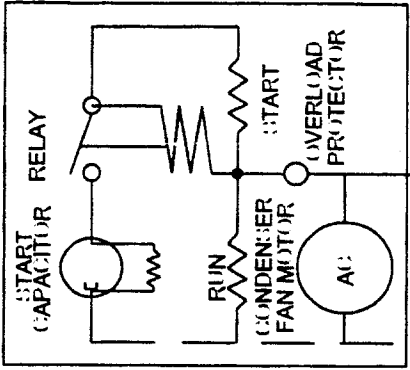

PRESSURE CONTROL

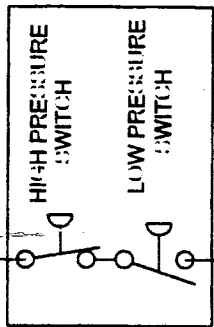

NOTE! FAN WIRING LEAD TABLE

FAN LEADS
RED (+) TERMINAL 2
BLACK (-) TERMINAL 3

HARNESS LEADS
SMOOTH WIRE (+) TERMINAL 2
GROVED WIRE (-) TERMINAL 3

CAREL THERMOSTAT

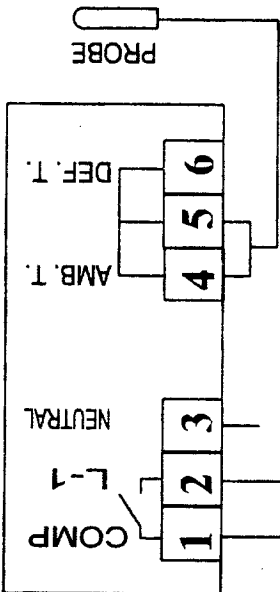

**TEMPEST-AIRE FAN
12VDC**

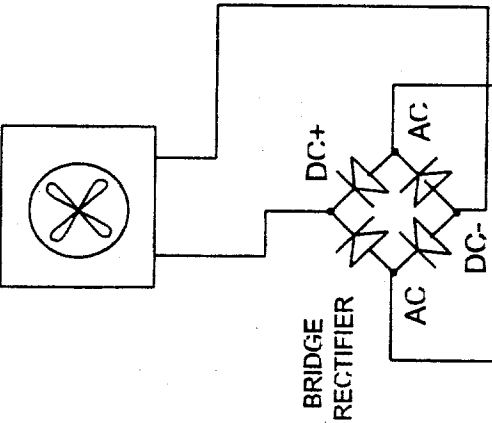

**TRANSFORMER
120V PRIMARY
12V SECONDARY**

LIQUID LINE SOLENOID

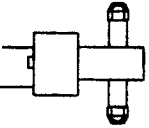

MASTER SWITCH



N L1

120V/1PH SERVICE REQUIRED

LOW TEMP INDUSTRIES INC.
JONESBORO, GA

WIRING DIAGRAM FOR
TEMPEST-AIRE 12 VOLT SINGLE WITH T-STAT

DATE: 3-10-10
DRAWING NO.
LT-ENG-WD-002C

REFRIGERATION SERVICE CHART

<u>COMPLAINT</u>	<u>PROBLEM</u>	<u>SOLUTION</u>
A. COMPRESSOR WILL NOT START	1. LINE DISCONNECT SWITCH OPEN 2. FUSE REMOVED OR BLOWN 3. CONTROL STUCK IN OPEN POSITION 4. CONTROL OFF DUE TO COLD LOCATION	1. CLOSE START OR DISCONNECT SWITCH 2. REPLACE FUSE 3. REPAIR OR REPLACE CONTROL 4. RELOCATE CONTROL
B. COMPRESSOR WILL NOT START, HUMS BUT TRIPS OVERLOAD PROTECTOR	1. LOW VOLTAGE TO UNIT 2. STARTING CAPACITOR DEFECTIVE 3. RELAY FAILING TO CLOSE 4. COMPRESSOR MOTOR HAS A WINDING OPEN OR SHORTED 5. INTERNAL MECHANICAL TROUBLE IN COMPRESSOR	1. CALL POWER SUPPLIER 2. REPLACE CAPACITOR 3. REPLACE RELAY 4. REPLACE COMPRESSOR 5. REPLACE COMPRESSOR
C. COMPRESSOR STARTS BUT DOES NOT SWITCH OFF OF START WINDING	1. LOW VOLTAGE TO UNIT 2. RELAY FAILING TO OPEN 3. RUN CAPACITOR DEFECTIVE 4. EXCESSIVELY HIGH DISCHARGE 5. COMPRESSOR MOTOR HAS A WINDING OPEN OR SHORTED 6. INTERNAL MECHANICAL TROUBLE IN COMPRESSOR	1. CALL POWER SUPPLIER 2. REPLACE RELAY 3. REPLACE CAPACITOR 4. CHECK DISCHARGE SHUT OVERCHARGE OR INSUFFICIENT COOLING CONDENSER. 5. REPLACE COMPRESSOR 6. REPLACE COMPRESSOR
D. COMPRESSOR STARTS AND RUNS, BUT SHORT CYCLES ON OVERLOAD PROTECTOR	1. LOW VOLTAGE TO UNIT 2. OVERLOAD PROTECTOR DEFECTIVE 3. RUN CAPACITOR DEFECTIVE 4. EXCESSIVE DISCHARGE PRESSURE 5. COMPRESSOR TOO HOT, RETURN GAS HOT 6. COMPRESSOR MOTOR HAS A WINDING SOUND	1. CALL POWER SUPPLIER 2. CHECK CURRENT, REPLACE PROTECTOR 3. REPLACE CAPACITOR 4. CHECK VENTILATION, RESTRICTIONS IN COOLING MEDIUM, RESTRICTIONS IN REFRIGERANT SYSTEM 5. CHECK REFRIGERANT CHARGE (FIX LEAK IF NECESSARY) 6. REPLACE COMPRESSOR
E. UNITS RUNS OK, BUT SHORT CYCLES ON	1. OVERLOAD PROTECTOR 2. THERMOSTAT 3. HIGH PRESSURE CUT OUT DUE TO: A. INSUFFICIENT AIR B. OVERCHARGE C. AIR IN SYSTEM 4. LOW PRESSURE CUT-OUT DUE TO:	1. SEE D-2 ABOVE 2. DIFFERENTIAL SET TOO CLOSE, WIDEN 3A. CHECK AIR SUPPLY TO CONDENSER 3B. REDUCE REFRIGERANT CHARGE 3C. PURGE

REFRIGERANT SERVICE CHART (CONT.)

<u>COMPLAINT</u>	<u>PROBLEM</u>	<u>SOLUTION</u>
	A. UNDERCHARGED	4A. FIX LEAK AND ADD REFRIGERANT
	B. EXPANSION VALVE OUT OF ADJUSTMENT.	4B. RE-ADJUST VALVE
	C. RESTRICTION IN EXPANSION VALVE.	4C. REPLACE VALVE
F. UNIT OPERATES LONG OR CONTINUOUSLY CLOSED	1. SHORTAGE OF REFRIGERANT 2. CONTROL CONTACTS STUCK OR REPLACE CONTROL 3. REFRIGERANT OR AIR CONDITIONED SPACE HAS EXCESSIVE LOAD OR POOR INSULATION 4. EVAPORATOR COIL ICED 5. RESTRICTION IN REFRIGERANT SYSTEM 6. DIRTY CONDENSER 7. FILTER DIRTY	1. FIX LEAK, ADD CHARGE 2. CLEAN CONTACTS, OR FROZEN 3. DETERMINE FAULT AND CORRECT CORRECT 4. DEFROST 5. DETERMINE LOCATION AND REMOVE SYSTEM 6. CLEAN CONDENSER 7. CLEAN OR REPLACE
G. START CAPACITOR OPEN	1. RELAY CONTACTS NOT OPENING PROPERLY 2. PROLONGED OPERATION ON START CYCLE DUE TO: A. LOW VOLTAGE TO UNIT B. IMPROPER RELAY 3. EXCESSIVE SHORT CYCLE	1. CLEAN CONTACTS OR REPLACE IF NECESSARY 2A. CALL POWER SUPPLIER 2B. REPLACE 3. DETERMINE REASON FOR SHORT CYCLE (SEE E. AND CORRECT)
H. RUN CAPACITOR OPEN, SHORTED OR BLOWN	1. IMPROPER CAPACITOR 2. EXCESSIVELY HIGH LINE VOLTAGE (100% OF RATED-MAX)	1. DETERMINE CORRECT SIZE AND REPLACE 2. CALL POWER SUPPLIER
I. SPACE TEMPERATURE TOO HIGH	1. CONTROL SETTING TOO HIGH 2. INADEQUATE AIR CIRCULATION	1. RESET (CONTROL) 2. IMPROVE AIR MOVEMENT
J. SUCTION LINE FROSTED OR SWEATING	1. EXPANSION VALVE STUCK 2. EVAPORATOR FAN NOT RUNNING 3. OVERCHARGE OF REFRIGERANT	1. CLEAN VALVE OF FOREIGN PARTICLES REPLACE IF NECESSARY 2. DETERMINE REASON AND CORRECT 3. CORRECT CHARGE

**REPLACEMENT PARTS LIST
MODEL DI-20 DROP IN TEMPEST AIRE COLD PAN
(THIS UNIT USES 507 REFRIGERANT)**

ITEM NO.	DESCRIPTION	STOCK NO.	MFG. NO.	MANUFACTURER
1	CONDENSING UNIT	311938	M4FL-0040-IAA	COPELAND
1A	COMPRESSOR	311999	AFE13C3E-IAA	COPELAND
1B	CONDENSING UNIT	311930	M4FF-0056-IAA	COPELAND
1C	COMPRESSOR	311950	RST45C1E-IAA	COPELAND
2	PRESSURE CONTROL	280610	012-4834-000	RANCO
3	FILTER / DRIER	282310	C-052-S-T	SPORLAN
4	SIGHT GLASS	282400	SA-12S	SPORLAN
5	EXPANSION VALVE	282572	Y1017-FP-1/6-ZP	SPORLAN
5A	EXPANSION VALVE	282579	Y1193-BIP-1/8-Z	SPORLAN
6	AXIAL FAN	312390	AQ1212HB-F51	JARO
7	120V/12V TRANSFORMER	312391	NTM402424-B41	JARD
8	BRIDGE RECTIFIER	312392	FB2500	FARGO
9	TOGGLE SWITCH	335900	90-0001	McGILL
9A	ROCKER SWITCH	335912	C1300XRBDR	CARLING
10	THERMOSTAT	280820	A12-700	RANCO
10A	THERMOSTAT	280860	PJEZSNH100	CAREL
10B	THERMOSTAT PROBE	280865	NTC030HP00	CAREL
11	LIQUID LINE SOLENOID	281610	E3S120W/ MKC-1-120V	SPORLAN

BASIC SYSTEM OPERATION (REFRIGERATION SYSTEM)

FOLLOWING SECTION IS DESIGNED TO GIVE A BASIC WORKING KNOWLEDGE OF OUR SYSTEM. IT SHOULD NOT BE USED AS A TRAINING MANUAL FOR NON-QUALIFIED REFRIGERATION TECHNICIANS.

ALL LOW TEMP IND REFRIGERATED EQUIPMENT EMPLOY A COMPRESSION CYCLE SYSTEM. THERE ARE TWO PRESSURES, WHICH EXIST IN A COMPRESSION SYSTEM; THE EVAPORATING OR LOW PRESSURE, AND THE CONDENSING OR HIGH PRESSURE.

THE REFRIGERANT WORKS AS A TRANSPORTATION MEDIUM TO MOVE HEAT FROM THE EVAPORATOR TO THE CONDENSER WHERE IT IS GIVEN OFF TO THE AMBIENT AIR. THE CHANGE OF STATE FROM LIQUID TO VAPOR AND BACK ALLOWS THE REFRIGERANT TO ABSORB AND DISCHARGE LARGE QUANTITIES OF HEAT EFFICIENTLY.

THE BASIC SYSTEM OPERATES AS FOLLOWS:

HIGH PRESSURE LIQUID REFRIGERANT IS FED FROM THE RECEIVER THROUGH THE LIQUID LINE AND THROUGH THE FILTER DRIER AND SIGHT GLASS TO THE EXPANSION VALVE, WHICH WORKS AS A METERING DEVICE SEPARATING THE HIGH PRESSURE SIDE OF THE SYSTEM FROM THE LOW PRESSURE EVAPORATOR.

THE THERMOSTATIC EXPANSION VALVE CONTROLS THE FEED OF LIQUID REFRIGERANT TO THE EVAPORATOR, AND BY MEANS OF AN ORIFICE REDUCES THE PRESSURE OF THE REFRIGERANT TO THE EVAPORATING OR LOW PRESSURE SIDE.

THE REDUCTION OF PRESSURE ON THE LIQUID REFRIGERANT CAUSES IT TO BOIL OR VAPORIZE UNTIL THE REFRIGERANT IS AT THE SATURATED TEMPERATURE CORRESPONDING TO ITS PRESSURE. AS THE LOW TEMPERATURE REFRIGERANT PASSES THROUGH THE EVAPORATOR COIL, HEAT FLOWS THROUGH THE WALLS OF THE EVAPORATOR TUBING TO THE REFRIGERANT, CAUSING THE BOILING ACTION TO CONTINUE UNTIL THE REFRIGERANT IS COMPLETELY VAPORIZED.

THE EXPANSION VALVE REGULATES THE FLOW THROUGH THE EVAPORATOR AS NECESSARY TO MAINTAIN A PRESET TEMPERATURE DIFFERENCE OR SUPER HEAT BETWEEN THE EVAPORATING REFRIGERANT AND VAPOR LEAVING THE EVAPORATOR. AS THE TEMPERATURE OF THE GAS LEAVING THE EVAPORATOR VARIES THE EXPANSION VALVE POWER ELEMENT BULB SENSES ITS TEMPERATURE, AND ACTS TO MODULATE THE FEED THROUGH THE EXPANSION VALVE AS REQUIRED.

THE REFRIGERANT VAPOR LEAVING THE EVAPORATOR TRAVELS THROUGH THE SUCTION LINE TO THE COMPRESSOR INLET. THE COMPRESSOR TAKES THE LOW PRESSURE VAPOR AND COMPRESSES IT, INCREASING BOTH THE PRESSURE AND THE TEMPERATURE. THE HOT, HIGH PRESSURE GAS IS FORCED OUT THE COMPRESSOR DISCHARGE VALVE AND INTO THE CONDENSER.

AS THE HIGH PRESSURE GAS PASSES THROUGH THE CONDENSER, IT IS COOLED BY A FAN BLOWING OVER A FIN-TYPE CONDENSER SURFACE. AS THE TEMPERATURE OF THE REFRIGERANT VAPOR REACHES THE SATURATION TEMPERATURE CORRESPONDING TO THE HIGH PRESSURE IN THE CONDENSER, THE VAPOR CONDENSES INTO A LIQUID AND FLOWS BACK INTO THE RECEIVER TO REPEAT THE CYCLE.

THE REFRIGERATION PROCESS IS CONTINUED AS LONG AS THE COMPRESSOR OPERATES. THE

COMPRESSOR OPERATION IS CONTROLLED BY A LOW PRESSURE CONTROL. WHEN THE REFRIGERANT VAPOR ENTERING THE SUCTION SIDE OF THE COMPRESSOR REACHES A PRESET VALUE ON THE CONTROL, IT WILL OPEN A SET OF CONTACTS AND SHUT THE COMPRESSOR OFF.

THE LOW PRESSURE IS SET BY A "CUT-IN" AND A "DIFFERENTIAL" SETTING. THE "CUT-IN" IS THE PRESSURE AT WHICH YOU WANT THE COMPRESSOR TO START. THIS PRESSURE CORRESPONDS TO THE TEMPERATURE OF THE EVAPORATOR SURFACE, WHICH MUST BE MAINTAINED. NOTE THAT AS A RULE OF THUMB ALL COLORPOINT UNITS HAVE APPROXIMATELY A 10 DEGREE FAHRENHEIT TEMPERATURE DIFFERENCE. BETWEEN THE EVAPORATOR COILS AND THE WORKING SURFACE. SO THE PRESSURE CORRESPONDING TO THE "CUT-IN" SHOULD BE 10 DEGREES LESS THAN THE OPERATING TEMPERATURE OF THE REFRIGERATED SURFACE. TO CUT THE UNIT OFF THE "DIFFERENTIAL" SETTING IS USED. FIRST CHOOSE THE TEMPERATURE SETTING AT, WHICH YOU WANT THE UNIT TO CUT OFF. THEN SUBTRACT FROM THE "CUT-IN" SETTING. THAT IS THE VALUE OF THE DIFFERENTIAL.

WARRANTY

ALL LOW TEMP FOOD SERVICE EQUIPMENT IS FULLY WARRANTED BY THE MANUFACTURER AGAINST DEFECTS IN MATERIALS OR WORKMANSHIP FOR A PERIOD OF **ONE (1) YEAR FOR PARTS AND FOR LABOR** FROM THE DATE OF PURCHASE BY THE ORIGINAL USER AND ONLY TO THE ORIGINAL PURCHASER PROVIDED IT IS INSTALLED AND OPERATED IN ACCORDANCE WITH THE INSTRUCTIONS SUPPLIED WITH THE UNIT. ALSO, IT MUST NOT BE MISUSED, ALTERED OR NEGLECTED AND USED ONLY ON CIRCUITS AND VOLTAGES REQUIRED FOR THAT UNIT.

OUR OBLIGATION UNDER THIS WARRANTY SHALL BE LIMITED TO ONE OF THE FOLLOWING PROCEDURES. SELECTION OF A PROCEDURE SHALL BE AT THE SOLE DISCRETION OF LOW TEMP INDUSTRIES INC.

LOW TEMP INDUSTRIES, INC. WARRANTY SERVICE DEPARTMENT MUST BE NOTIFIED PRIOR TO ANY SERVICE WORK FOR A WARRANTY AUTHORIZATION NUMBER. ANY REQUESTS FOR WARRANTY CLAIMS WITHOUT A WARRANTY AUTHORIZATION NUMBER, WILL NOT BE HONORED.

- A. REPLACEMENT OF DEFECTIVE PARTS, SHIPPED F.O.B. FACTORY, IN EXCHANGE FOR THE RETURNED DEFECTIVE PART, SHIPPED PREPAID FREIGHT.
- B. FREE REPLACEMENT OF DEFECTIVE PART, SHIPPED F.O.B. FACTORY.
- C. DEFECTIVE PART SHIPPED PREPAID FREIGHT TO FACTORY, REPAIRED AND RETURNED, SHIPPED F.O.B. . FACTORY.
- D. ALL LABOR COSTS SHALL BE COVERED FOR A PERIOD OF 1 YEAR FROM THE DATE OF PURCHASE.

LOW TEMP INDUSTRIES INC. SHALL NOT BE RESPONSIBLE FOR ANY DAMAGE CAUSED BY FIRE, FLOOD, WINDSTORM, OR ANY OTHER ACT OF GOD; WAR, WHETHER DECLARED OR UNDECLARED NOR SHALL WE BE RESPONSIBLE FOR THE LOSS OF FOOD OR OTHER PRODUCTS DUE TO POWER OR MECHANICAL FAILURE. THIS WARRANTY SHALL NOT COVER ANY DAMAGE CAUSED DURING SHIPMENT WHICH SHOULD BE REPORTED TO THE DELIVERING CARRIER.

LOW TEMP MANUFACTURING COMPANY

**A DIVISION OF LOW TEMP INDUSTRIES INC.
9192 TARA BOULEVARD
JONESBORO, GEORGIA 30236
(770) 478-8803**

FIVE YEAR COMPRESSOR WARRANTY

ALL LOW TEMP MECHANICALLY REFRIGERATED EQUIPMENT CARRIES AN EXTENDED COMPRESSOR WARRANTY BY LOW TEMP INDUSTRIES, INC.

THIS EXTENDED WARRANTY BEGINS ON THE EXPIRATION DATE OF THE ONE (1) YEAR WARRANTY BY THE COMPRESSOR MANUFACTURER AND WARRANTS THE COMPRESSOR AGAINST DEFECTS IN MATERIALS OR WORKMANSHIP FOR A PERIOD OF FOUR (4) YEARS TO THE ORIGINAL USER AND ONLY TO THE ORIGINAL PURCHASER PROVIDED IT IS INSTALLED AND OPERATED IN ACCORDANCE WITH THE INSTRUCTIONS SUPPLIED WITH THE UNIT.

THIS WARRANTY COVERS ONLY THE COMPRESSOR AND DOES NOT INCLUDE ANY RETURN SHIPPING CHARGES, OTHER TRANSPORTATION CHARGES, ANY EXTERNAL PARTS OR ELECTRICAL COMPONENTS, LABOR, REFRIGERANTS OR TAXES.

WARRANTY SHALL BE VOID IF THE UNIT HAS BEEN MISUSED, ALTERED OR NEGLECTED. THE SERIAL NUMBER SHALL NOT BE REMOVED OR DEFACED, AND THE UNIT SHALL BE USED ONLY ON CIRCUITS AND VOLTAGES REQUIRED FOR THAT UNIT.

OUR OBLIGATION UNDER THIS EXTENDED WARRANTY SHALL BE LIMITED TO ONE OF THE FOLLOWING PROCEDURES:

A. REPLACEMENT OF DEFECTIVE COMPRESSOR, SHIPPED FREIGHT PREPAID, IN EXCHANGE FOR THE RETURNED DEFECTIVE COMPRESSOR, SHIPPED PREPAID FREIGHT.

B. REPLACEMENT OF DEFECTIVE COMPRESSOR AT A LOCAL REFRIGERATION SUPPLY HOUSE, IN EXCHANGE FOR THE DEFECTIVE COMPRESSOR.

NO REPLACEMENT OF COMPRESSOR(S) WILL BE AUTHORIZED UNDER EXTENDED WARRANTY WITHOUT ACCURATE VERIFICATION OF SERIAL NUMBER(S) OF DEFECTIVE COMPRESSOR(S).

LOW TEMP INDUSTRIES, INC. MUST BE NOTIFIED PRIOR TO COMPRESSOR REPLACEMENT FOR A WARRANTY AUTHORIZATION NUMBER. ANY REQUESTS FOR WARRANTY CLAIMS WITHOUT A WARRANTY AUTHORIZATION NUMBER, WILL NOT BE HONORED.

THIS EXTENDED WARRANTY DOES NOT COVER ANY DAMAGES CAUSED BY FIRE, FLOOD, WINDSTORM, OR ANY OTHER ACT OF GOD; WAR, WHETHER DECLARED OR UNDECLARED NOR SHALL BE RESPONSIBLE FOR THE LOSS OF FOOD OR OTHER PRODUCTS DUE TO POWER OR MECHANICAL FAILURE.

**LOW TEMP INDUSTRIES INC.
9192 TARA BOULEVARD
JONESBORO, GEORGIA 30236
(770) 478-8803**